

2020 CATALOGUE

FIRE-PROTECTION

PASSIVE FIRE PROTECTION

**GLUE &
SCREW SYSTEM**

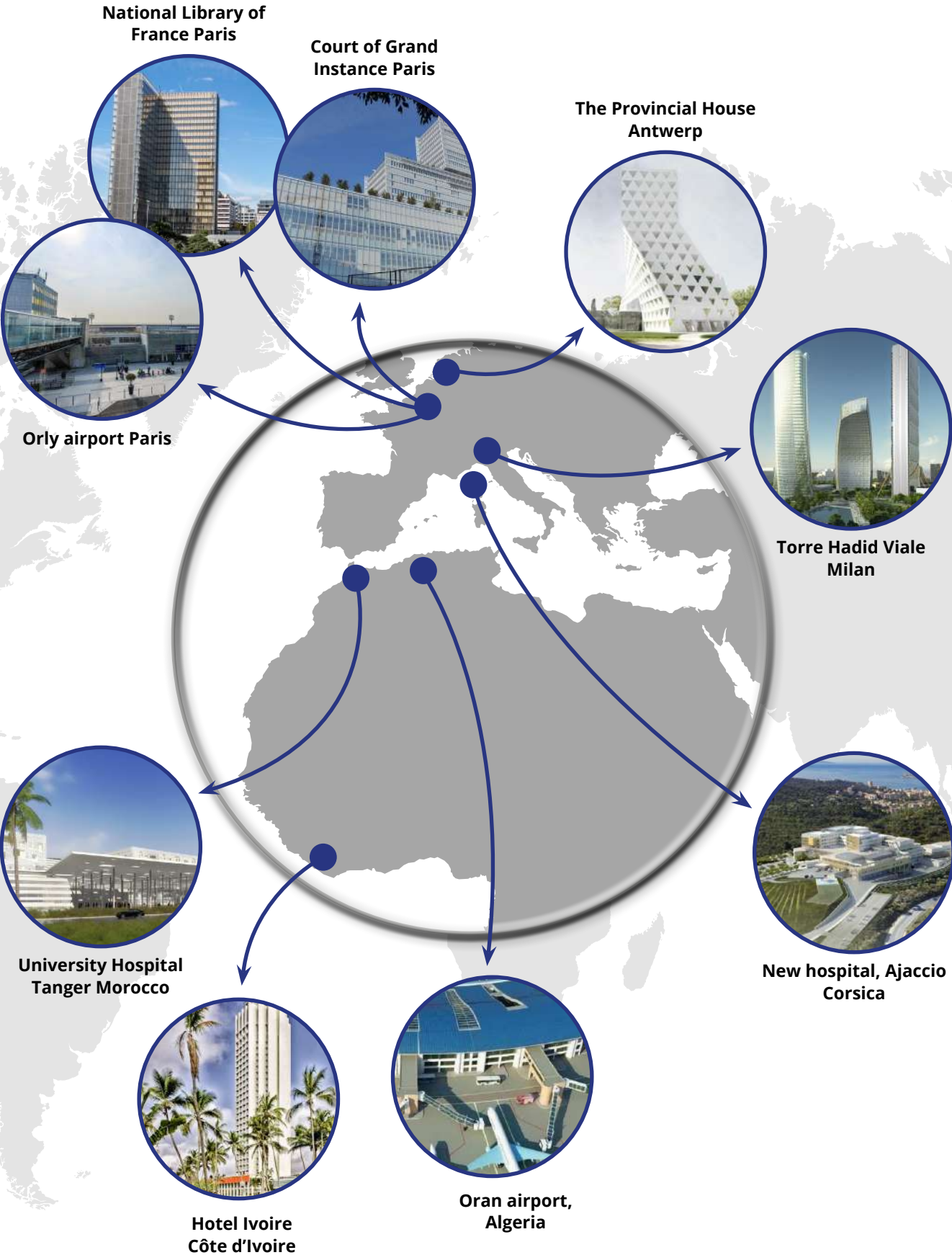

A few site references: CDG airport, Roissy – Palais des Congrès – Stade de France – Necker hospital, Paris 15 – Lille Metro – Stade de Lille – Ritz hotel - Paris-Orly airport – Melun hospital – Trocadero Business Centre – Grand Louvre – Georges V hotel – Presidential palace, Congo – AIG Tour Majunga – Toulon military hospital.

GENERAL OVERVIEW	5
• INTRODUCTION	5
• PASSIVE FIRE PROTECTION	6
TECHNICAL DATASHEETS	10
• GEOTEC®S FIRE-PROTECTION BOARDS	10
• GEOTEC®SX FIRE-PROTECTION BOARDS	11
• GEOFLAM®C LIGHT CHANNELS	12
• GEOTEC®A / GEOFLAM®A U-PLASTER ELEMENTS	13
• GEOTEC®A / GEOFLAM®A 1/2 SHELLS	14
• GEOTEC®A / GEOFLAM®A REINFORCEMENT COLLARS & COVER STRIPS	15
• EXPANSION JOINT ELEMENTS & GEOTEC®A BATTENS	16
• GEOCOL® / GEOCOL®S ADHESIVE	17
• POLYURETHANE FOAM / ROPE BEADING	18
SMOKE EXTRACTION AND VENTILATION DUCTS	20
• ASSESSMENTS	20
• SYSTEM OVERVIEW	21
• HORIZONTAL SMOKE EXTRACTION AND VENTILATION DUCTS	22
• VERTICAL SMOKE EXTRACTION AND VENTILATION DUCTS	28
• INSTALLATION OF SMOKE EXTRACTION SHUTTERS	32
• ADDITIONAL TECHNICAL DATA	33
FIRE PROTECTION OF SERVICE DUCTS AND SHAFTS	35
• ASSESSMENTS	35
• SYSTEM OVERVIEW	36
• HORIZONTAL SYSTEM	37
• OTHER HORIZONTAL CONFIGURATIONS	38
• VERTICAL SYSTEM	38
• FIRE PROTECTION OF SERVICE DUCTS WITH 2 OR 3 FACES	40
PROTECTION FOR CARBON FIBRE BONDED BEAMS	42
• SYSTEM OVERVIEW	42
• BONDED CARBON FIBRE BEAM PROTECTION	43
ADDITIONAL FIRE-PROTECTION PRODUCTS	45
• GEOSYSTEM® - FP INSPECTION HATCHES TECHNICAL DATASHEET	45
• GEOSYSTEM® - FP INSPECTION HATCHES OVERVIEW	46
• OTHER FP INSPECTION HATCHES TECHNICAL DATASHEET	49
• OTHER FP INSPECTION HATCHES OVERVIEW	50
• VENTILATION GRILLES TECHNICAL DATASHEET	51



INTRODUCTION

■ Who are we?

For 35 years GEOSTAFF has been specialising in fire-protection products intended for passive fire protection, all specially designed to meet the highest building industry standards.

A European manufacturer of 100% natural GRG* products, GEOSTAFF offers the following product ranges:

- **GEOTEC®** and **GEOFLAM®** for constructing ventilation and smoke extraction ducts, fire-protection casings, shells for stabilising metal columns against fire and protection for bonded carbon-fibre beams.
- **GEODECO®** decorative range manufactured for the decoration of hotel suspended ceilings, luxury homes and castles.

Our two product ranges, GEOTEC® and GEOFLAM®, enable us to provide our customers with cutting-edge solutions for the protection of persons and buildings in the event of fire.

* GRG : Glass-Reinforced Gypsum.

■ Choosing the Geostaff solution

By choosing Geostaff fire-protection products you can now have the solution that best fits your needs.

- 19 one-hour fire-protection board references
- 20 two-hours fire-protection board references
- A new single size Geotec®SX board : 1200 x 1000 mm (Lxw) for easy cutting and assembly.
- 100% natural gypsum-based products giving the products lightness and strength
- Pre-moulded, easy-to-install fire-protection accessories
- Various options for installing Geostaff products
 - > Glue & screw system
 - > Glue & staple system
 - > Mixture of sisal fibers and bonding plaster
- A software tool for your calculations is available directly on our website: www.geostaff.fr
- Products made in our factories in France, meeting all European quality standards in addition to **CE*** certification under a **DOP***.
- Meeting environmental and health standards (Fiche de Déclaration Environnementale et Sanitaire: FDES) and observing safety standards (Fiche de Données de sécurité : FDS)

*CE : Conformité Européenne (European Conformity)

*DOP : Declaration Of Performance.

Protecting you from fire is what we do

▪ Passive fire protection

Passive protection involves incorporating fire-protection systems within the structures so as to limit the spread of fire.

Passive fire protection means:

- Protection of personnel, allowing the occupants to evacuate the building in complete safety,
- Protection of property, containing the fire for as long as possible while awaiting the emergency services.

▪ Ventilation and smoke extraction ducts

The construction of a ventilation or smoke extraction system involves using a flow of air to flush the space to be cleared of smoke.

This means clearing smoke on the one hand (smoke extraction duct or high-level ventilation) and bringing in fresh air on the other (ventilation duct or low-level ventilation).

Two cases are therefore possible:

- Protecting the internal volume of a duct from fire, the common expression "external fire" using **ventilation ducts or introduction of air** (low-level ventilation);
- In the rooms that it crosses, protecting the entire length of ducting from an "internal" fire, using **smoke extraction ducts** (high-level ventilation).

▪ Application of our products

- Installation of vertical and horizontal smoke extraction and ventilation ducts
- Encasing electrical cable trays, gas pipes and other services...
- Protection of carbon fibre bonded beams
- All our fire-protection products are designed for all types of building (private, public, industrial, etc.) and have a fire resistance time from 1 hour to 4 hours (EI 60 to 240)
- All our fire-protection products can be painted with acrylic paints without altering their fire resistant properties.



■ Fire resistance tests and classification standards

Geostaff products are tested and classified in accordance with all European standards are in force.

Fire resistance classification standards

EN 13501-3

Fire classification of products and constructional elements
- Part 3: Classification using fire resistance test data for the products and elements used in maintenance installations: fire-resistant ducts and one-way shutters.

EN 13501-4

Fire classification of products and constructional elements
- Part 4: Classification based on fire resistance test data for the components of smoke control devices.

Standards for fire resistance tests

EN 1366-1

Fire resistance tests for plant installations
- Part 1: Ducts.

To obtain a ventilation duct certificate, tests in accordance with EN 1366-1 (horizontal and/or vertical ducts type A and B, as defined in the standard) are required.

EN 1366-8

Fire resistance tests for service installations
- Part 8: Smoke extraction ducts.

To obtain a certificate for a smoke extraction duct, tests in accordance with EN 1366-1 and 8 (horizontal and/or vertical ducts type A, B and C, as defined in the standard) are required.

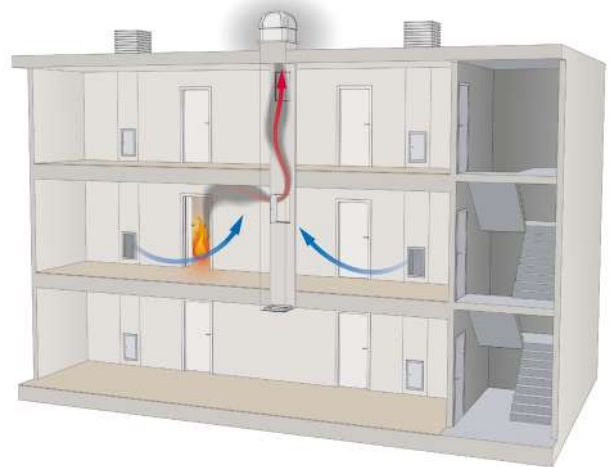
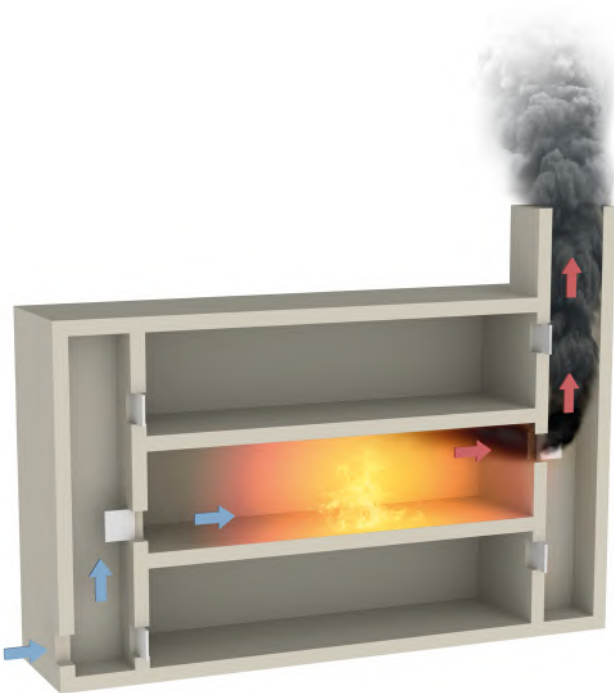

PASSIVE FIRE PROTECTION

Classification criteria

- E**: Opaque to flames and hot gases
- I**: Thermal insulation (temperature on the unexposed side < 140°C on average or 180°C at a point)
- t**: Duration of the classification expressed in minutes
- S**: Sealing against smoke (leakage per unit surface area < 10 m³/hr.m² for ventilation, 5 m³/hr.m² for smoke extraction)
- ve**: Vertical position of the duct being tested
- ho**: Horizontal position of the duct being tested
- o --> i**: Direction of the "external" fire
- i --> o**: Direction of the "internal" fire
- i <--> o**: Arbitrary direction of the "internal" or "external" fire
- Multi**: Indicates that the smoke extraction duct can extract smoke from several compartmentalised zones
- Service pressure**: Indicates the positive and negative pressures at which the duct was tested

Example of classification

EI 60 vertical ventilation duct (formerly 1 hr fire-break)

E	I	t	ve	ho	i	<-->	o	S
E	I	60	ve		i	<-->	o	S

EI 120 horizontal smoke extraction duct (formerly 2 hr fire-break)

E	I	t	S	ve	ho	Service pressure	Multi
E	I	120	S		ho	-1500/+500	Multi

Marking

To guarantee the performance of our fire protection systems, Geostaff decided, by means of a daily product inspection, to implement annual certification audits to obtain CE marking of fire-protection boards.

CE marking was created in the context of European legislation and certifies that our products conform to the declared levels of performance.

For all Geostaff products with the CE marking, the Declarations of Performance for these products are available on the www.geostaff.fr website





Dimensions

Thickness (mm)	EI (mm)	Board dimensions* (L x w) (mm)	Weight after baking (kg/m ²)	Rebated sides	Rebates (mm)
30	60	200 to 1100 x 1000	22.5	2	14 x 16
45	120	200 to 1100 x 1000	34	4	22 x 23

E = Fire sealing / I = Thermal insulation
* Per 50 mm step

Product description

GEOTEC®S boards, composed primarily of plaster and glass fibre, are intended for passive fire protection.

Application

- Horizontal and vertical ventilation and smoke extraction ducts
- Fire-protection of service ducts and shafts
- Protection of carbon fibre bonded beams
- Protection for cable trays
- EI 60 to 120 (1 hr to 2 hr fire-break).

Implementation

GEOTEC®S boards are assembled using adhesive and woodscrews or polochons* : mixture of sisal fibers and bonding plaster (interior and exterior), or using staples. They can be cut using any means.

Finish

Placed with the smooth surface facing inwards to improve the flow of air, or outwards to give a clean, finished appearance.

A water-based acrylic paint may be applied to GEOTEC®S products without compromising their fire-protection properties.

Transportation and storage

Transport and store on a flat, protected surface. Keep away from water.

- + It is possible to apply a water-repellent treatment that does not alter the A1 classification by addition of water-repellent.
- + Immediate availability for all board sizes.

Characteristics of GEOTEC®S* boards

Reaction to fire	A1 in accordance with EN 13501-1
Nominal density (± 15%)	± 750 kg/m ³
Bending strength	≥ 1.3 MPa
Compressive strength	≥ 3 MPa
pH value	approximately 8.5
Thermal conductivity coeff (λ at 20°C)	0.106 W/m.K
Resistance to water vapour diffusion (μ)	± 3
Roughness factor (ε)	0.05 mm
Cold sealing class	D
Acoustic attenuation Rw (C; Ctr)	29 (-2; -2) dB for thickness 30 mm
	31 (-1; -2) dB for thickness 45 mm
Dimensional tolerance	± 5 mm
Thickness tolerance	± 2 mm
Colour	White
Appearance	Smooth
Machinability	Excellent

* The data in this table are average values, given for information only. If certain properties are essential for some particular application, we should preferably be consulted.



ATE 18/0343 based on EAD 350142-00-1106



Dimensions

Thickness (mm)	EI (mm)	Board dimensions* (L x w) (mm)	Weight after baking (kg/m ²)	Rebated sides	Rebates (mm)
30	60	1200 x 1000	22.5	2	14 x 16
45	120	1200 x 1000	34	2	22 x 23

E = Fire sealing / I = Thermal insulation

Product description

GEOTEC®SX boards, made primarily of plaster and glass fibre, are intended for passive fire protection.

These boards, in a single size of 1200 x 1000 mm (L x w) have no longitudinal rebates for ease of cutting and assembly.

Application

- Horizontal and vertical ventilation and smoke extraction ducts
- Fire-protection of service ducts and shafts
- Protection of carbon fibre bonded beams
- Protection for cable trays
- EI 60 to 120 (1 hr to 2 hr fire-break).

Implementation

GEOTEC® SX boards are assembled using adhesive and woodscrews or polochons* : mixture of sisal fibers and bonding plaster (interior and exterior), or using staples. They can be cut using any means.

Finish

Placed with the smooth surface facing inwards to improve the flow of air, or outwards to give a clean, finished appearance.

A water-based acrylic paint may be applied to **GEOTEC® SX** products without compromising their fire-protection properties.

Transportation and storage

Transport and store on a flat, protected surface. Keep away from water.

✚ It is possible to apply a water-repellent treatment that does not alter the A1 classification by addition of water-repellent.

Characteristics of GEOTEC®SX* boards

Reaction to fire	A1 in accordance with EN 13501-1
Nominal density (± 15%)	± 750 kg/m ³
Bending strength	≥ 1.3 MPa
Compressive strength	≥ 3 MPa
pH value	approximately 8.5
Thermal conductivity coeff (λ at 20°C)	0.106 W/m.K
Resistance to water vapour diffusion (μ)	± 3
Roughness factor (ε)	0.05 mm
Cold sealing class	D
Acoustic attenuation Rw (C; Ctr)	29 (-2; -2) dB for thickness 30 mm
	31 (-1; -2) dB for thickness 45 mm
Dimensional tolerance	± 5 mm
Thickness tolerance	± 2 mm
Colour	White
Appearance	Smooth
Machinability	Excellent

* The data in this table are average values, given for information only. If certain properties are essential for some particular application, we should preferably be consulted.



ATE 18/0343 based on EAD 350142-00-1106



Product description

GEOTEC®C Light channels, made primarily of plaster and glass fibre, are intended for passive fire protection.

These 35 mm thick elements are pre-moulded with longitudinal rebates and ends that allow them to be interlocked.

Application

- Fire-protection of service ducts for gas, medical fluids and various kinds of pipework
- Protection for electrical cable trays up to a fire exposure of EI 120 (2 hr fire-break)

Implementation

Assembly is by bonding all the joint surfaces of horizontal and vertical junctions. This module, in an open U shape, is closed with a **GEOFLAM®C Light** cover and glued. These elements can be cut with a handsaw, sabre saw or circular saw.

Finish

A water-based acrylic paint may be applied to **GEOFLAM®C Light** products without compromising their fire-protection properties.

Transportation and storage

Transport and store on a flat, protected surface. Keep away from water.

Dimensions

Thickness (mm)	EI (mm)	Length (m)	Internal dimensions (L x w) (mm)	Weight after baking* (kg/m)
35	120	1	50 x 50	16
			100 x 50	20
			100 x 100	24
			150 x 100	28
			150 x 150	32,50
			200 x 100	11
			200 x 200	40,50
			300 x 100	41
			350 x 200	53

E = Fire sealing / I = Thermal insulation
*Channel & Cover

Characteristics of GEOFLAM®C Light channels

Reaction to fire	A1 in accordance with EN 13501-1
Nominal density (± 15%)	± 1100 kg/m ³
Bending strength	≥ 1.8 MPa
Compressive strength	≥ 5 MPa
pH value	Approximately 8.9
Dimensional tolerance	± 5 mm
Thickness tolerance	± 2 mm
Colour	White
Appearance	Smooth
Machinability	Excellent

* The data in this table are average values, given for information only. If certain properties are essential for some particular application, we should preferably be consulted.

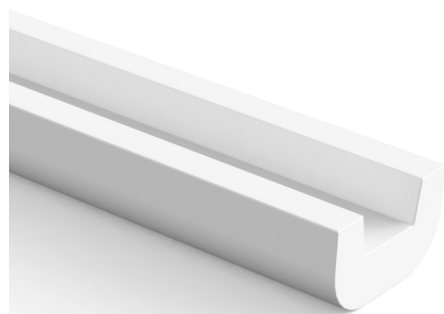

Dimensions

EI (mm)	Length (m)	Dimensions (h x L) (mm)
60 to 120	1	55 x 110*
60 to 120		60 x 100
180		70 x 100
60 à 180		85 x 120

E = Fire sealing / I = Thermal insulation
 *Only for GEOTEC® ducts

Product description

Consisting mainly of plaster and glass fibre, these pre-moulded elements are intended to protect metal cross-pieces.

Application

Protection for the metal supports of horizontal **GEOTEC®** and **GEOFLAM®A** ducts, EI 60 to 180 (1 hr to 3 hr fire-break).

Implementation

The U-plaster fire-protection elements are brought together and bonded. These elements can be cut with a handsaw, sabre saw or circular saw.

Transportation and storage

Transport and store on a flat, protected surface. Keep away from water.

Reaction to fire
A1 classification in accordance with standard EN 13501-1

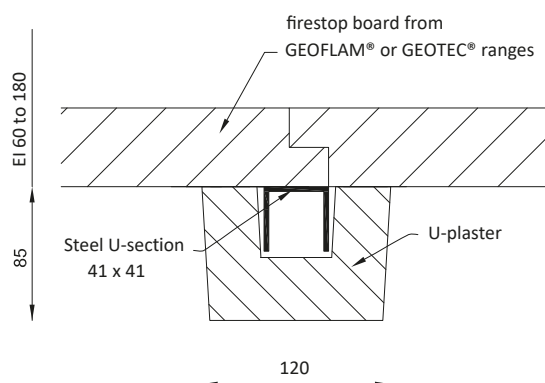
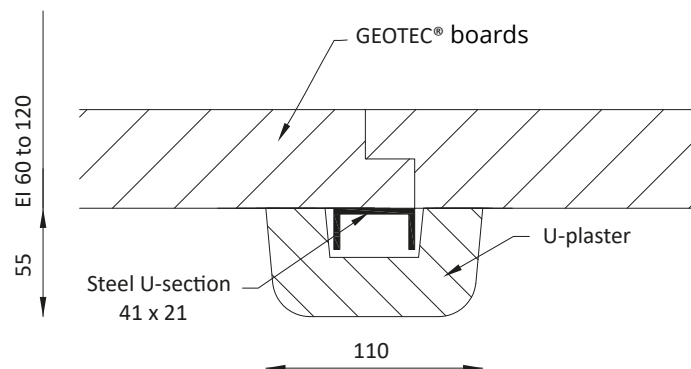
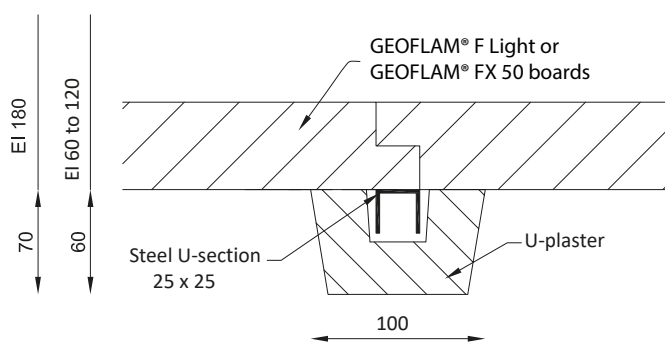



Dimensions

EI (mm)	Length (m)	Dimensions (h x L) (mm)
60 to 120	1	90
180		130

E = Fire sealing / I = Thermal insulation

Product description

Pre-moulded elements designed to protect threaded rods. The 1/2 shells are made primarily of plaster and glass fibre.

Application

Protection for the metal supports of horizontal **GEOTEC®** and **GEOFLAM®** ducts, EI 60 to 180 (1 hr to 3 hr firestop).

Implementation

The **GEOTEC®A** 1/2 shell fire-protection elements are assembled with adhesive. These elements can be cut with a handsaw, sabre saw or circular saw.

Transportation and storage

Transport and store on a flat, protected surface. Keep away from water.

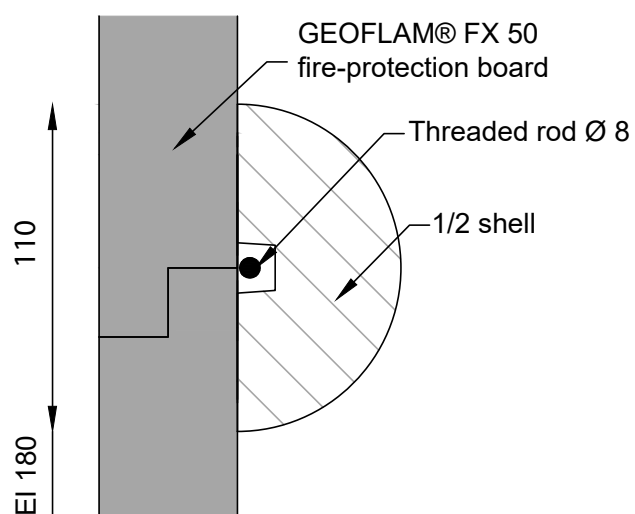
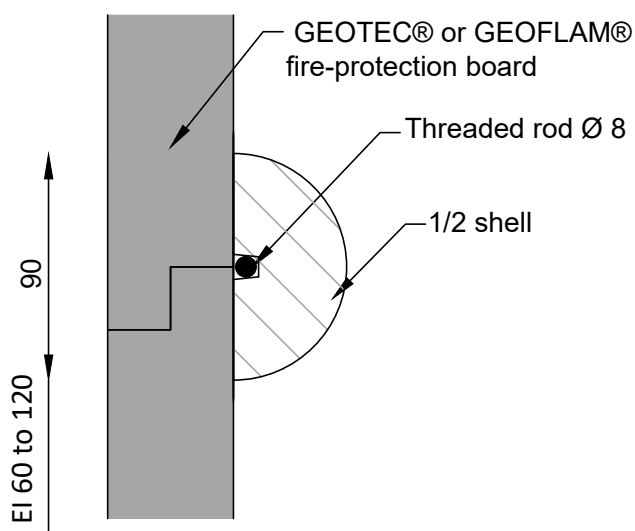

Reaction to fire
A1 classification in accordance with standard EN 13501-1

GEOTEC®A / GEOFLAM®A REINFORCEMENT COLLARS

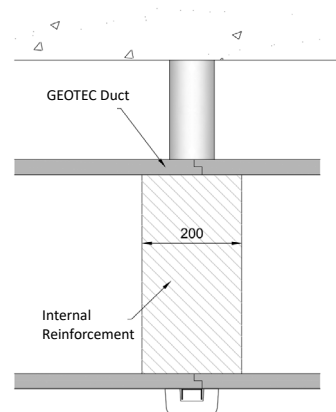
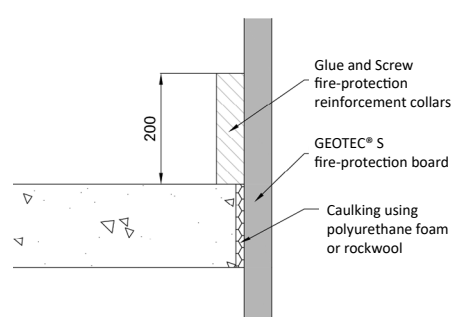

Product description

Made primarily of plaster and glass fibre, **GEOTEC®A / GEOFLAM®A** reinforcement collars are used to support vertical ducts and service ducts.

They can equally be applied as internal reinforcement for horizontal ducts if necessary.

Application

These 200 mm high elements, positioned at the base of vertical ducts or inside horizontal ducts, must be of the same thickness as the duct.

Implementation

These elements can be cut with a handsaw, sabre saw or circular saw.

Transportation and storage

Transport and store on a flat, protected surface. Keep away from water.

Dimensions

Duct thickness (mm)	Thickness of reinforcement collars (mm)	EI (mm)	Length (m)	Height (mm)
30	60	120	1	200
45	120			

E = Fire sealing / I = Thermal insulation

GEOTEC®A COVER STRIPS

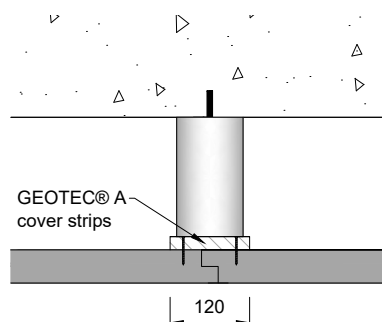
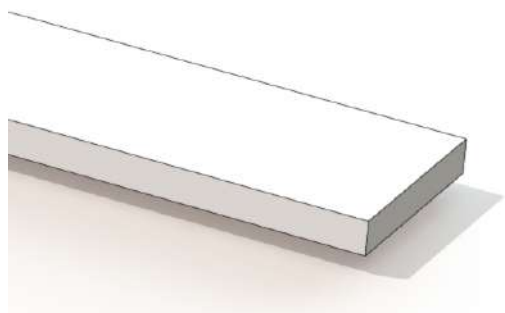

Product description

Made mainly of plaster and glass fibre, **GEOTEC®A** cover strips are designed to reinforce the upper boards of horizontal ducts and service ducts.

Application

These cover strips must be used at the upper transverse joints of horizontal ducts and service ducts, either internally or externally.

Implementation

These elements can be cut with a handsaw, sabre saw or circular saw.

Transportation and storage

Transport and store on a flat, protected surface. Keep away from water.

Dimensions

Thickness (mm)	EI (mm)	Length (m)	Width (mm)
20	60 to 120	1	120

E = Fire sealing / I = Thermal insulation

GEOTEC®A / GEOFLAM®A EXPANSION JOINT ELEMENTS

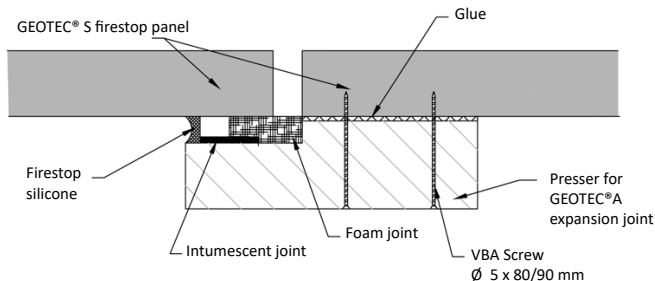

Product description

Plaster and glass fibre pre-moulded element 1.5 m long, bonded around the perimeter of the ducts serving as a presser for inserting of foam and intumescent joints; this is intended to take up the various displacements of the structure as it moves.

Application

For use on **GEOTEC®** ducts in expansion joints for concrete structures.

Implementation

These elements can be cut with a handsaw, sabre saw or circular saw.

Transportation and storage

Transport and store on a flat, protected surface. Keep away from water.

Dimensions

Thickness (mm)	EI (mm)	Length (m)	Width (mm)
60	60 to 120	1.5	200

E = Fire sealing / I = Thermal insulation

GEOTEC®A BATTENS

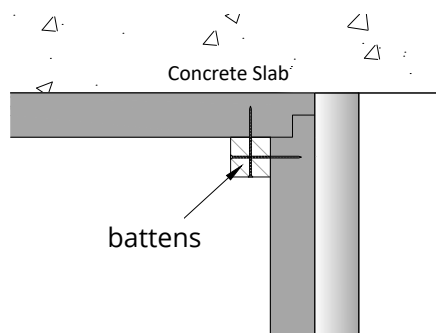
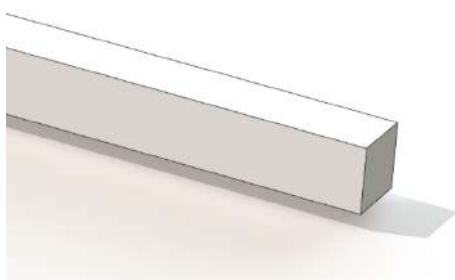

Product description

Made primarily of plaster and glass fibre, **GEOTEC®A** battens are used to facilitate screwing beadings together when the ducts or shrouds are juxtaposed with the wall or floor-slab.

Application

These 45 x 45 mm elements are positioned inside the inner corners of the ducts or service ducts so as to allow the boards to be screwed to one another.

Implementation

These elements can be cut with a handsaw, sabre saw or circular saw.

Transportation and storage

Transport and store on a flat, protected surface. Keep away from water.

Dimensions

Thickness (mm)	EI (mm)	Length (m)	Width (mm)
45	60 to 120	1	45

E = Fire sealing / I = Thermal insulation

GEOCOL® ADHESIVE

**Product description**

A thick adhesive in powder form specially formulated for mounting **GEOFLAM®** and **GEOTEC®** boards.

Also bonds various building materials: plasterboard, plaster tiles, cellular concrete blocks, etc.

Can also be used as a finish coating on most substrates.

Technical characteristics

A1 reaction to fire in accordance with standard EN 13501-1

Sticking time: roughly 2 hours depending on ambient conditions

Packaging and storage

25 kg bags

Store in a cool dry place protected from frost and heat.

Usable life: 12 months in the original, unopened packaging

GEOCOL®S ADHESIVE

**Product description**

GEOCOL®S ready-to-use adhesive is a non-flammable, sodium silicate based adhesive. This is specially formulated for mounting **GEOTEC®S** boards.

The adhesive is white or light grey in colour.

Technical characteristics

A1 reaction to fire in accordance with standard EN 13501-1

Drying time: 12 to 24 depending on ambient conditions

Packaging and storage

15 kg tubs

Store in a cool dry place protected from frost and heat.

Usable life: 12 months in the original, unopened packaging

POLYURETHANE FOAM



Product description

Soudafoam FR is a single-part, self-expanding polyurethane foam that can be used upside down. Soudafoam FR serves to ensure the degree of fire resistance of ducts and conduits passing through walls.

Technical characteristics

Base: Polyurethane
Consistency: Stable foam
Curing system: Polymerisation due to humidity in the air
Resistance to temperature: -40°C to + 90°C (cured)

Packaging and storage

750 ml aerosol can
Always store Soudafoam FR in an upright position in a cool dry place. The foam will last for 12 months in its closed packaging.

ROPE BEADING



Product description

Ensuring the degree of fire resistance for expansion joints, beading ropes are available in diameters from 20 to 60 mm.

Technical characteristics

Material: Basalt "bio soluble" mineral fibres
Density: $270 \pm 25 \text{ kg /m}^3$
Melting temperature: 1200°C
Complete immersion water absorption at 20°C: 11 to 12 %, saturation after 7 days, returns to initial weight in 48 hours.
Good acoustic and thermal insulation, $0.08 \text{ W/m}^2\text{K}$

Packaging

20 m roll



ASSESSMENTS

Tests in accordance with EN 1366-1 and EN 1366-8	Thickness (mm)	EFFECTIS classification documents	Internal cross-sections (mm)	Service pressure (Pa)	EI S i↔o multi	Max ht
Horizontal and vertical ventilation	30	Cert EFR-16-002202 Rev. 1	0x0 to 2500x1500	± 500	60	7 m (2 battens) 10 m (3 battens)
	45				120	
Horizontal and vertical smoke extraction	30	Cert. EFR-16-002203 Rev. 1	0x0 to 2500x1500	-1500/+500	60	
	45				120	

E = Fire-tightness / I = Thermal insulation / S = Smoke-tightness / i ↔ o = internal or external fire

NB: Documentation exists also for rope beading versions:
Cert. EFR-16-002204 Rev. 1 and EFR-16-002205 Rev. 1

Extensions to EFR-16-002202 Rev. 1 and EFR-16-002203 Rev. 1

Extension 17/6 and 7	<i>Various support principles for horizontal ducts</i>
Extension 17/5 and 6	<i>Various principles for supporting vertical ducts</i>
Extension 16/3 and 4	<i>Expansion joint treatment for GEOTEC® ducts</i>
Extension 17/4 and 5	<i>Assembling GEOTEC® ducts using staples</i>
Extension 17/5 and 6	<i>Construction of EI 240 ducts (Mounting using rope beading only)</i>
Extension 18/9 and 10	<i>Operation of GEOTEC® ducts up to a maximum positive pressure of + 1500 Pa</i>
Extension 19/13	<i>Non protection of metal supports for ventilation ducts ≤ 20 dm²</i>

Laboratory Appraisals

APL EFR-17-001582	<i>Non-traversing ducts (horiz. and vert.)</i>
APL EFR-17-000808	<i>Construction of trapezoidal and triangular smoke extraction ducts (Mounting using rope beading only)</i>
APL EFR-16-003921	<i>Construction of trapezoidal and triangular ventilation ducts (Mounting using rope beading only)</i>

Compatibility with smoke extraction shutters

Manufacturer	Tunnel shutters	Gate shutters
RF-Technologies	EI 60 S to EI 120 S	EI 60 S to EI 120 S
Aldes		
Panol		
France Air		

SYSTEM OVERVIEW

Ducts are made by juxtaposing **GEOTEC®S** boards of length 1000 mm and of 30 or 45 mm thickness. These systems are available for fire classifications EI 60 to EI 120 (in accordance with standards EN 13501-3 and EN 13501-4). All boards are moulded to standard dimensions and rebated on all four sides for ducts 45 mm thick, and on two sides for ducts 30 mm thick; this helps with their assembly. Each 1000 mm long cuttable segment comprises four or more boards.

■ Certificates: fire resistance classification report

All our systems are subjected to tests carried out by official institutions. The reports of these tests form the basis for the certification of our smoke extraction and ventilation systems.

- Classification in accordance with EN 13501-1, EN 13501-3 and EN 13501-4
- CE Certification (in accordance with EAD 350142-00-1106)

+ To make your assemblies easier, Geostaff always uses the same size of threaded rod and steel U-sections.

HORIZONTAL SYSTEM

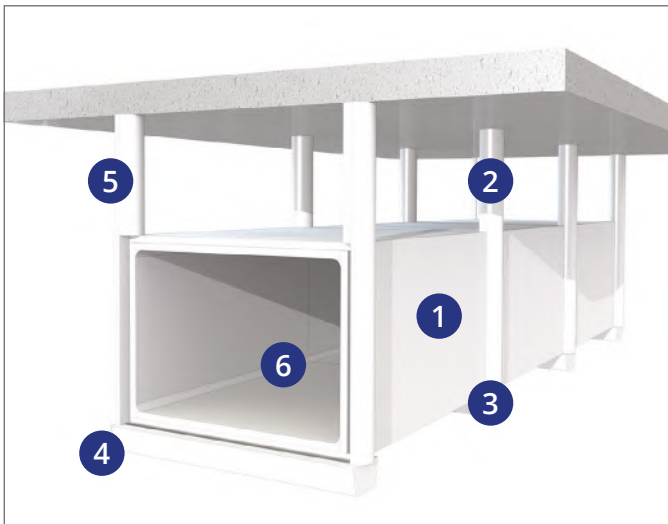

- 1 GEOTEC®S 30 or GEOTEC®S 45 fire-protection boards (EI 60 and 120)
- 2 GEOTEC®A 1/2 shells
- 3 GEOTEC®A U-plaster
- 4 21x41x21 steel U and Ø8 nut
- 5 Ø8 pin and threaded rod
- 6 GEOCOL® or GEOCOL®S adhesive

VERTICAL SYSTEM

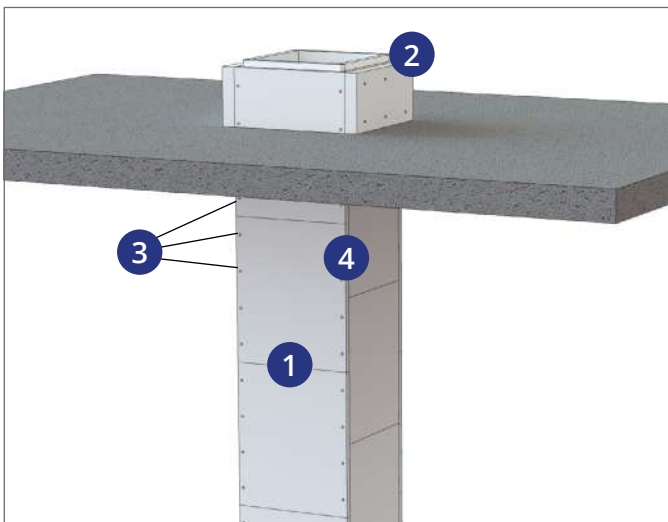

- 1 GEOTEC®S 30 or GEOTEC®S 45 fire-protection boards (EI 60 and 120)
- 2 GEOTEC®A* reinforcement collar
- 3 Woodscrew
- 4 GEOCOL® or GEOCOL®S adhesive

* Other load-bearing methods p.30

HORIZONTAL SMOKE EXTRACTION AND VENTILATION DUCTS

Principle of assembly

The boards are assembled at an angle (so as to make a duct of rectangular section) using woodscrews. Screws are inserted without pilot holes and must be accurately at right angles to the board surface. All joints are previously treated with **GEOL®** or **GEOL®S**.

Horizontal ducts are formed from 1000 mm sections; the boards are mounted with no offset on the horizontal and vertical joints. However, to make installation easier, the upper boards may be offset.

+ To make it even easier, Geostaff has put pre-perforated rails in place.

TRANSVERSE SECTION

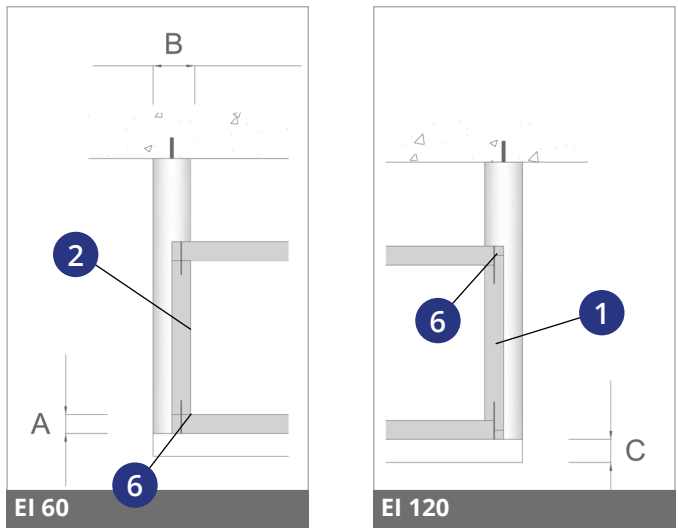

	A	B	C	D
EI 60	30 mm	90 mm	5 mm	1000 mm
EI 120	45 mm	90 mm	5 mm	1000 mm

- 1 GEOTEC®S 45 fire-protection boards
- 2 GEOTEC®S 30 fire-protection boards
- 3 GEOTEC®A 1/2 shells
- 4 GEOTEC®A U-plaster
- 5 Ø8 Rod
- 6 Ø5x90 mm woodscrew (45 mm)
Ø5x80 mm (30 mm)
- 7 21x41x21 pre-perforated (or otherwise) steel U-section

LONGITUDINAL CROSS-SECTION

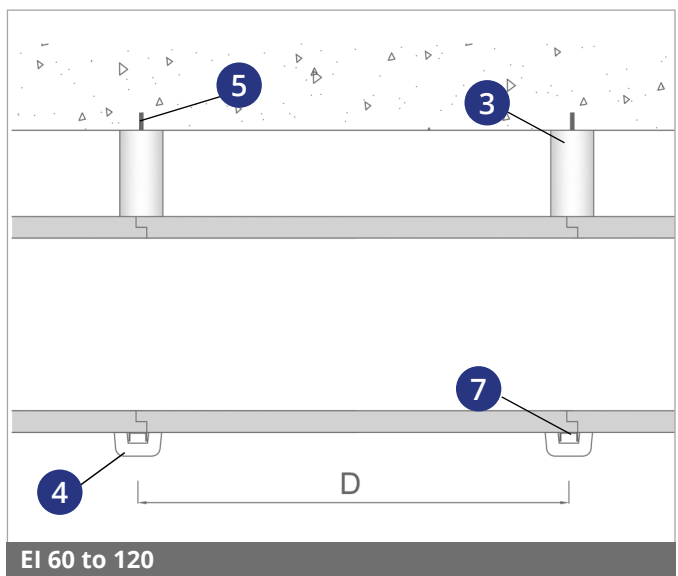

+ Any spaces of less than 10 mm between board junctions must be filled in over the entire thickness with **GEOL®** or **GEOL®S** adhesive.

+ Any potential repairs may also be treated by bonding and screwing an extra thickness of the board with an overlap equivalent to the thickness of the panel.

Average consumption

GEOL® adhesive: 2 kg/m²
GEOL®S adhesive: 0.750 kg/m²
Woodscrews: 36 per linear metre of duct.

HORIZONTAL SMOKE EXTRACTION AND VENTILATION DUCTS

Steps for installing GEOTEC®S horizontal ducts

1



- Mark out every 1000 mm
- Drill Ø10 holes
- Install Ø8 pins
- Screw up the Ø8 threaded rods

2



- Install steel U-sections every 1000 mm

3



- Install the lower board

4



- Glue the board edges
- Screw the side boards with woodscrews every 120 mm

5



- Glue the board rebates
- Install the upper board
- Screw with woodscrews every 120 mm or use staples

6



- Glue and install the protective plaster U-sections against the underside of the lower board

7



- Glue and install the 1/2 shells to protect the threaded rods

8



- Recommence at step 3
- Glue and fit together with the previous section

HORIZONTAL SMOKE EXTRACTION AND VENTILATION DUCTS

■ Reinforcement implementation on horizontal ducts

When building horizontal GEOTEC®S ducts, it is necessary to install strengthening every metre where the sections meet if the inner width is between **600 and 1000 mm**.

Two solutions may be used: using internal stiffeners or using external or internal joint-covers.

INTERNAL STIFFENERS (THICKNESS IDENTICAL TO THAT OF THE BOARD)

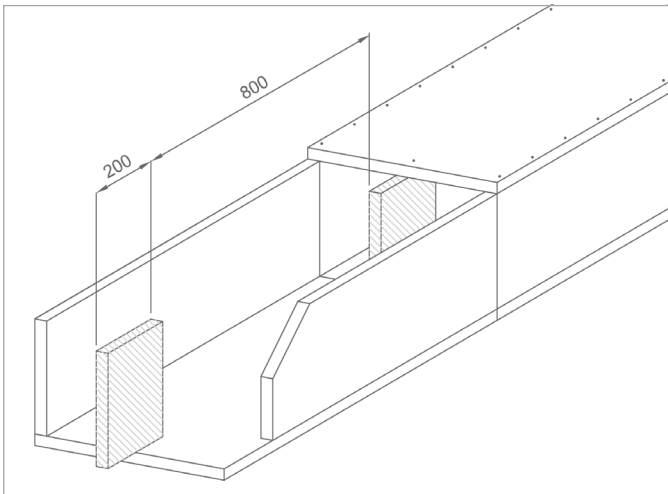

COVER STRIPS OUTSIDE OR INSIDE THE DUCT (120 X 20 MM)

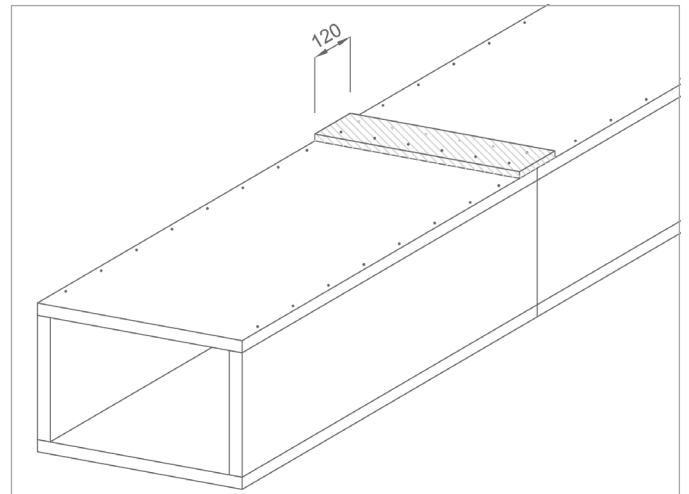

■ Construction of ducts of large cross-section

As far as horizontal GEOTEC®S ducts of internal width greater than 1000 mm are concerned, their construction involving juxtaposing boards width-wise, the principle of installation

should be as shown below in order to accommodate the upper duct boards.

INTERNAL WIDTH BETWEEN 1001 AND 1250 MM

In this configuration, a second 21x41x21 steel U-section must be installed inside to support the upper boards of the duct. In the case of a duct where there is a risk of internal fire, it must also be protected using a GEOTEC® A U-plaster element.

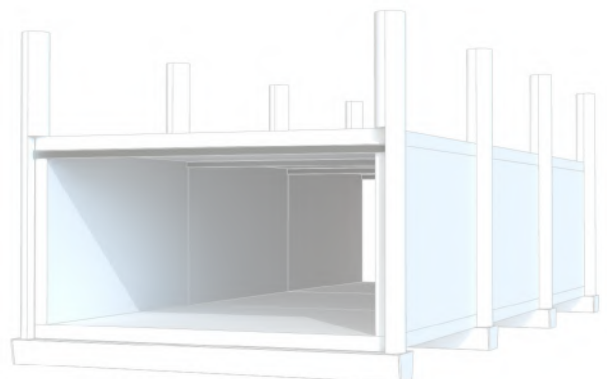
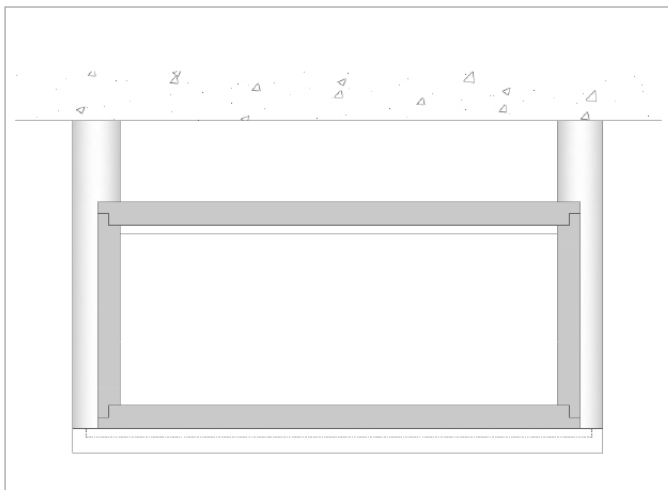

HORIZONTAL SMOKE EXTRACTION AND VENTILATION DUCTS

INTERNAL WIDTH BETWEEN 1251 AND 2500 MM

In this configuration, a second 21x41x21 steel U-section, as well as an additional Ø8 threaded rod, must be installed inside to support the upper boards of the duct.
 In the case of a duct where there is a risk of internal fire (smoke extraction), it must also be protected using GEOTEC® A U-plaster element and 1/2 shells.

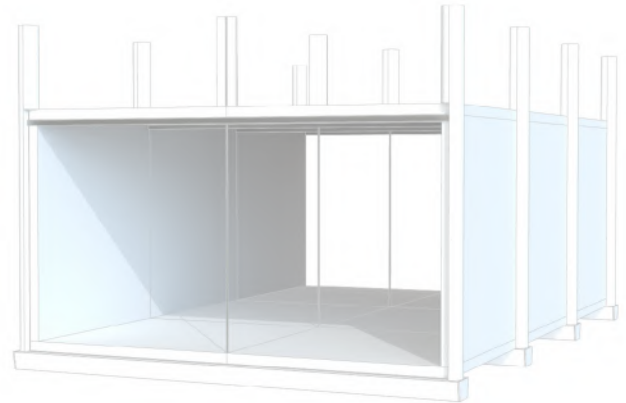
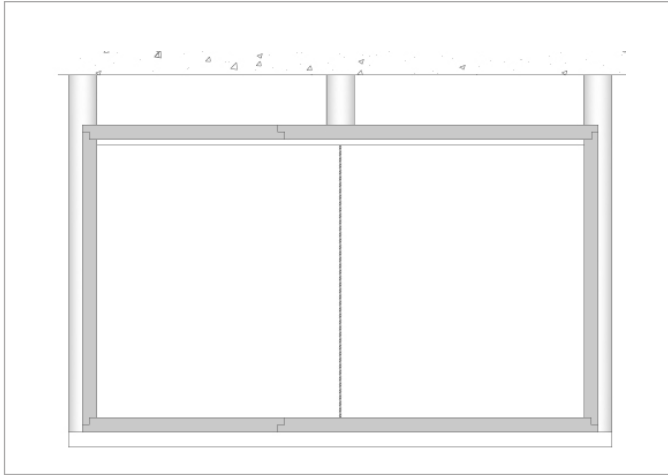

+ Other support principles are also available in extension 17/6 and 7 in certs. EFR-16-002202 Rev 1 and EFR-16-002203 Rev 1

SMOKE EXTRACTION AND VENTILATION DUCTS

Other methods for the protection of threaded rods and steel U-sections

With the constant aim of making it easier to install GEOTEC® S ducts, extensions 18/8 and 9 of assessments EFR-16-002202 and EFR-16-002203 have been validated to offer an alternative to the protection of threaded rods and steel U-sections.

The **GEOTEC®A** 1/2 shells used to protect the threaded rods may therefore be replaced by a protection in the form of GEOTEC®S panels or GEOTEC®A U-plaster element normally used to protect the steel U-sections.

The **GEOTEC®A** U-plaster element used for protecting the steel U-sections may thus be replaced by a protection in the form of GEOTEC®S boards.

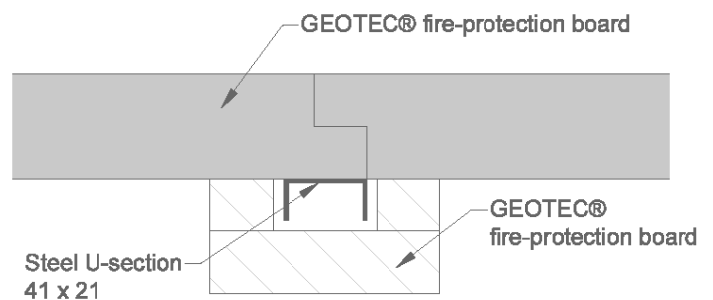
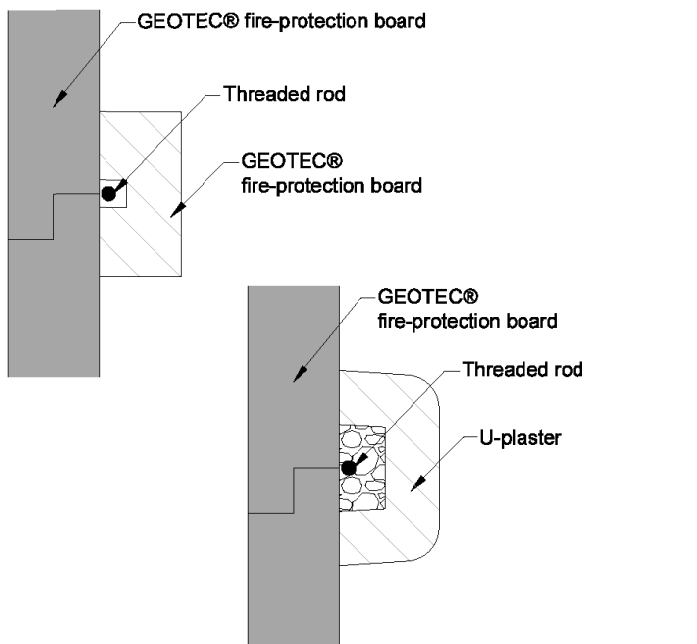

HORIZONTAL SMOKE EXTRACTION AND VENTILATION DUCTS

Method of caulking a horizontal duct where it passes through a wall

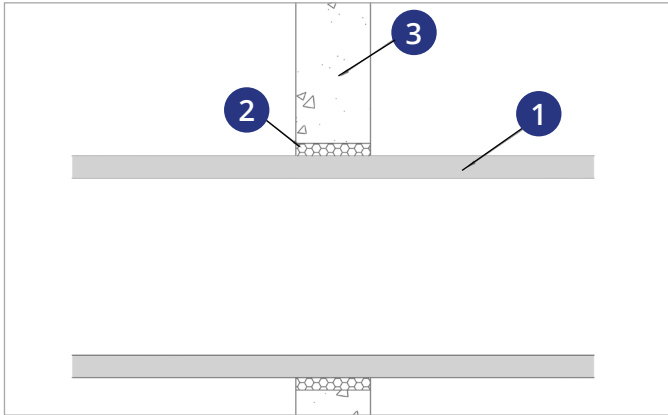

- 1 Horizontal GEOTEC®S duct
- 2 Caulking (approx. 25 mm)
- 3 Vertical wall

+ Caulking may be carried out using polyurethane foam or rockwool (26 kg/m³ minimum)

METHOD OF CAULKING A NON-TRAVERSING HORIZONTAL DUCT

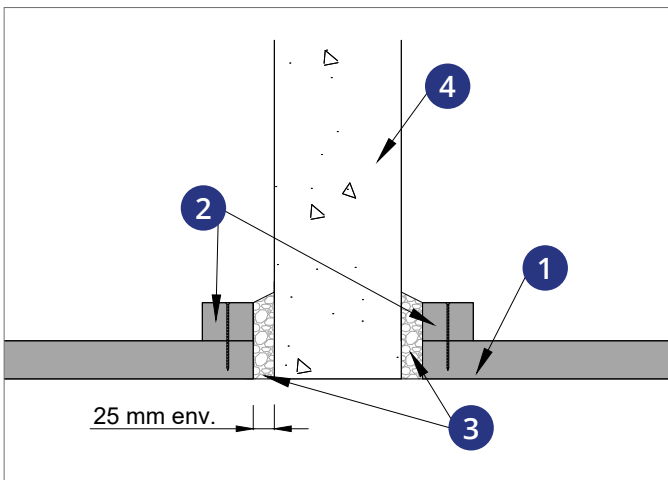

- 1 Horizontal GEOTEC®S duct
- 2 GEOTEC®S reinforcement collars of 60 mm x duct thickness
- 3 GEOCOL® adhesive (approx. 25 mm)

TRAVERSE OF LIGHTWEIGHT PLASTERBOARD PARTITIONS

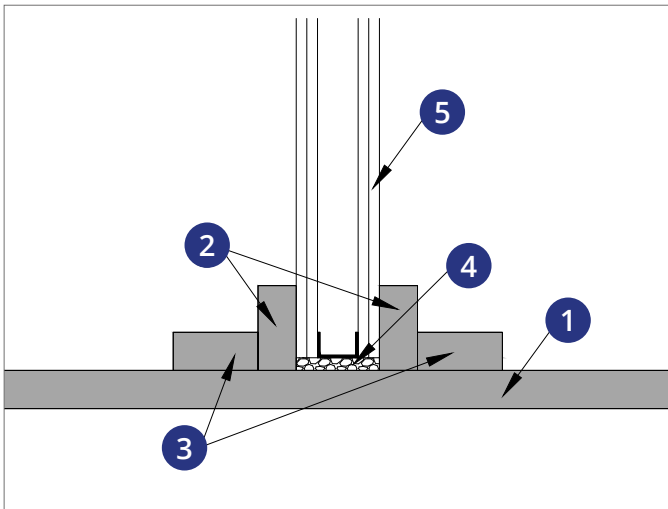

- 1 Horizontal GEOTEC®S duct
- 2 GEOTEC®S reinforcement collars of 100 mm x duct thickness
- 3 L-shaped reinforcement collars of 100 mm x duct thickness

+ Caulking may be carried out using polyurethane foam or rockwool (26 kg/m³ minimum)

HORIZONTAL SMOKE EXTRACTION AND VENTILATION DUCTS

■ Protection of steel ventilation ducts

The GEOTEC® product range also allows the protection of existing steel ventilation ducts, in accordance with extension 16/3 of assessments EFR-16-002202 and EFR-16-002204, by directly applying GEOTEC®S boards around the duct.

These existing ventilation ducts may be made of galvanised or stainless sheet steel and must have their own system of support.

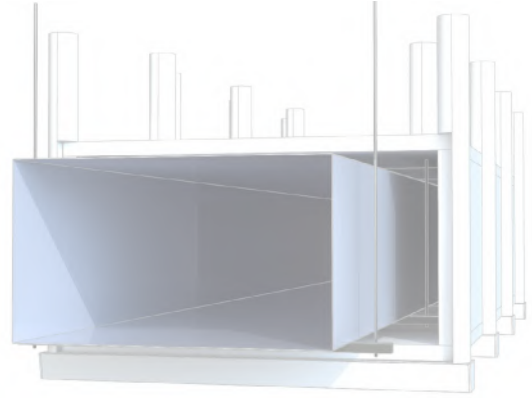
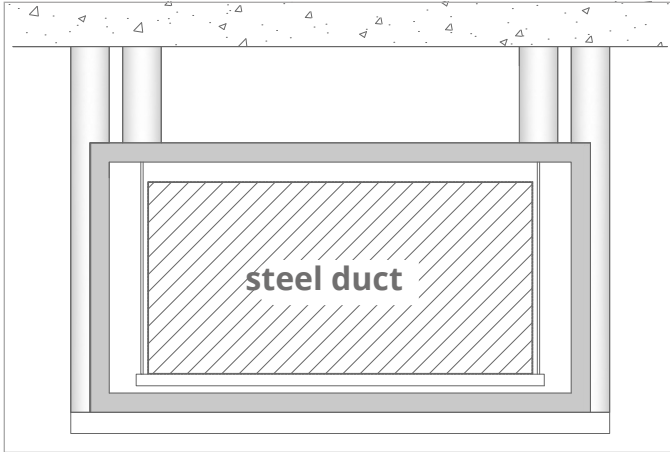

■ Other configurations

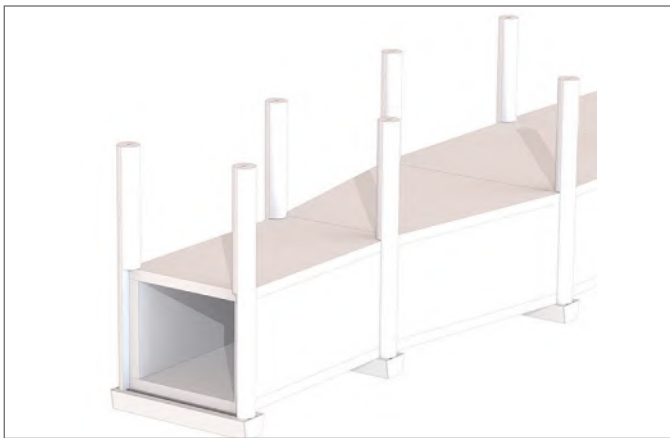

Change of cross-section



Corner connection

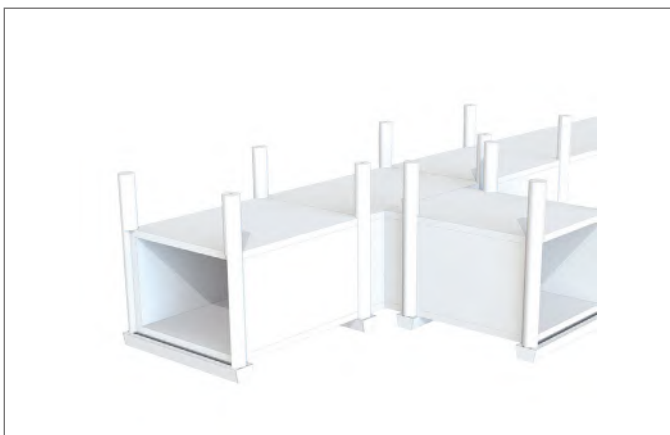

Take-off point on horizontal duct



Sloping

VERTICAL SMOKE EXTRACTION AND VENTILATION DUCTS

■ Principle of assembly

The boards are assembled at an angle (so as to make a duct of rectangular section) using woodscrews. Screws are inserted without pilot holes and must be accurately at right angles to the board surface. All joints must have been previously treated with GEOCOL® or GEOCOL®S.

When constructing vertical ducts, the board joints are offset between 2 contiguous faces (between 200 and 800 mm) so as to achieve optimal mechanical strength for the duct.

TRANSVERSE SECTION

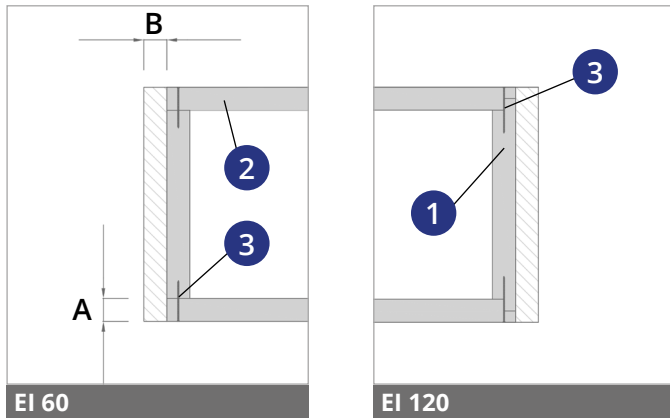

	A	B
EI 60	30 mm	30 mm
EI 120	45 mm	45 mm

- 1 GEOTEC®S 45 fire-protection boards
- 2 GEOTEC®S 30 fire-protection boards
- 3 Ø5x90 mm woodscrew (45 mm)
Ø5x80 mm (30 mm)
- 4 GEOTEC®A reinforcement collars
- 5 Caulking using PU foam or rockwool

DIAGRAM

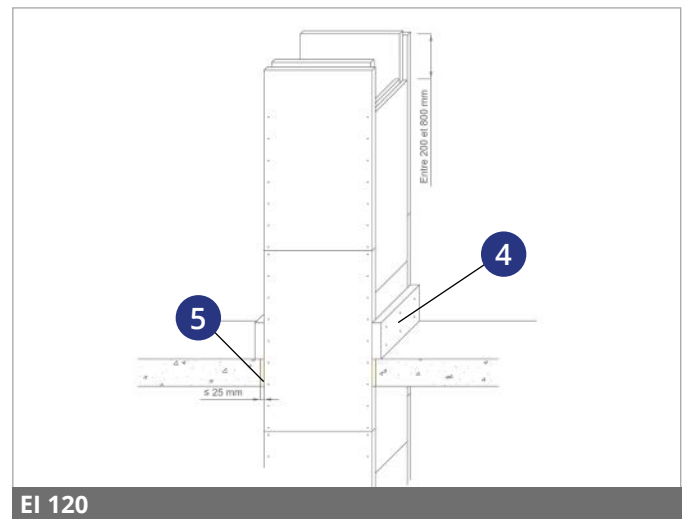
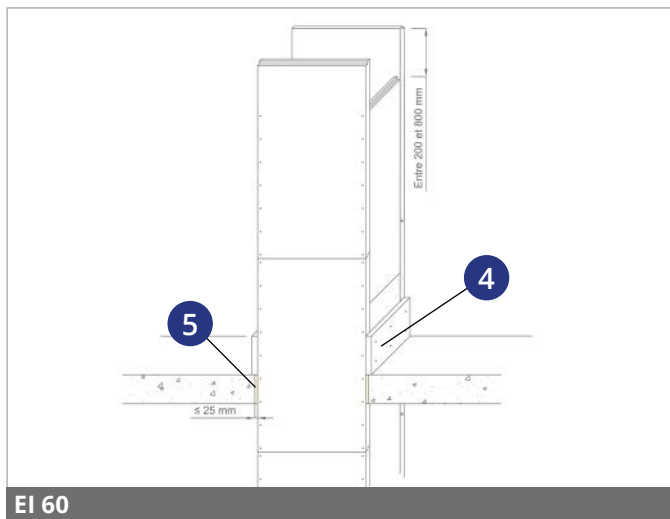

■ Method of caulking a vertical duct where it crosses a wall

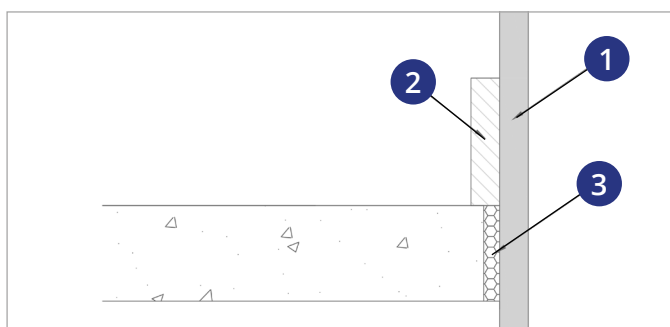

- 1 Vertical GEOTEC®S duct
- 2 GEOTEC®A load-bearing reinforcement collars
- 3 Caulking (approx. 25 mm)

+ Caulking may be carried out using polyurethane foam or rockwool (26 kg/m³ minimum)

VERTICAL SMOKE EXTRACTION AND VENTILATION DUCTS

Steps for installing GEOTEC®S vertical ducts



- Placing the 1st board on the ground

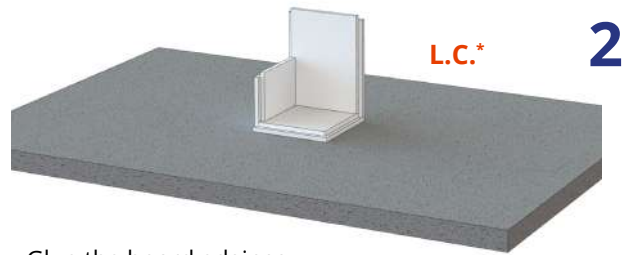

- Glue the board edges
- Screw the 2 contiguous panels with woodscrews every 120 mm
- Observe an offset of 200 to 800 mm between the horizontal joints

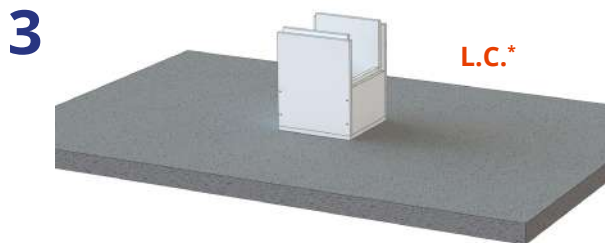

- Glue the board edges
- Place the other 2 vertical boards forming the 1st chamber
- Screw the boards together with woodscrews every 120 mm

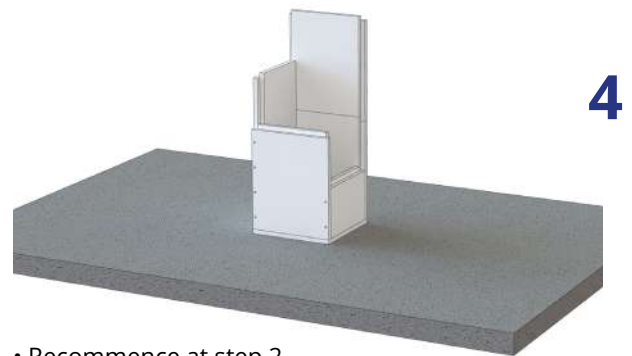

- Recommence at step 2
- Glue and fit together with the previous sections

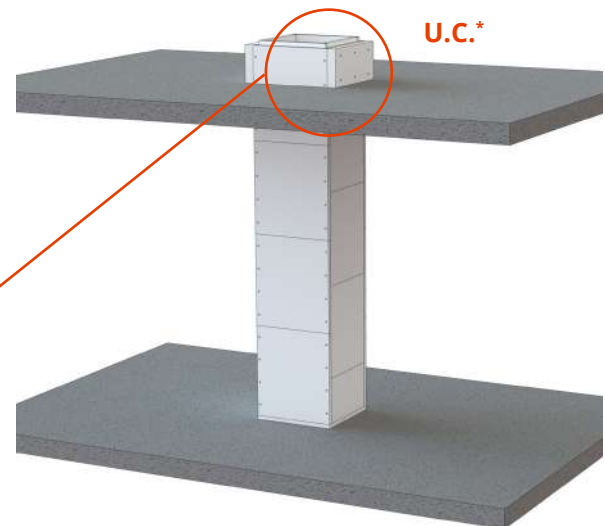
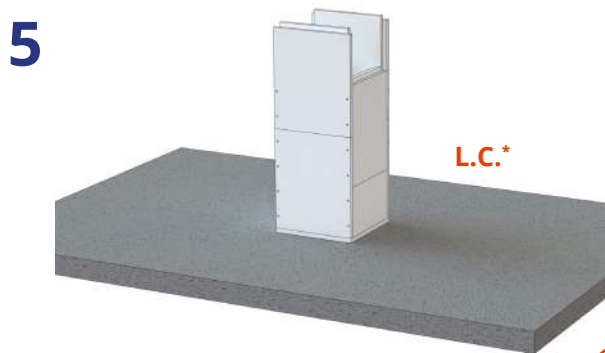

- Using glue and screws place the reinforcement collars on 2 sides of the duct bearing on the floor (Height limited to 7 m with 2 supports, and to 10 m with 3)*

*Various load-bearing principles (see page 30)

*L.C.: Lower ceiling - U.C.: Upper ceiling

VERTICAL SMOKE EXTRACTION AND VENTILATION DUCTS

▪ Load carrying

Height limited to 7 m with 2 supports, and to 10 m with 3.

Support by 2 parallel corner-pieces on floor-slab upstands

Support by 1 reinforcement collar on the floor & 1 corner piece in parallel with the floor-slab upstand

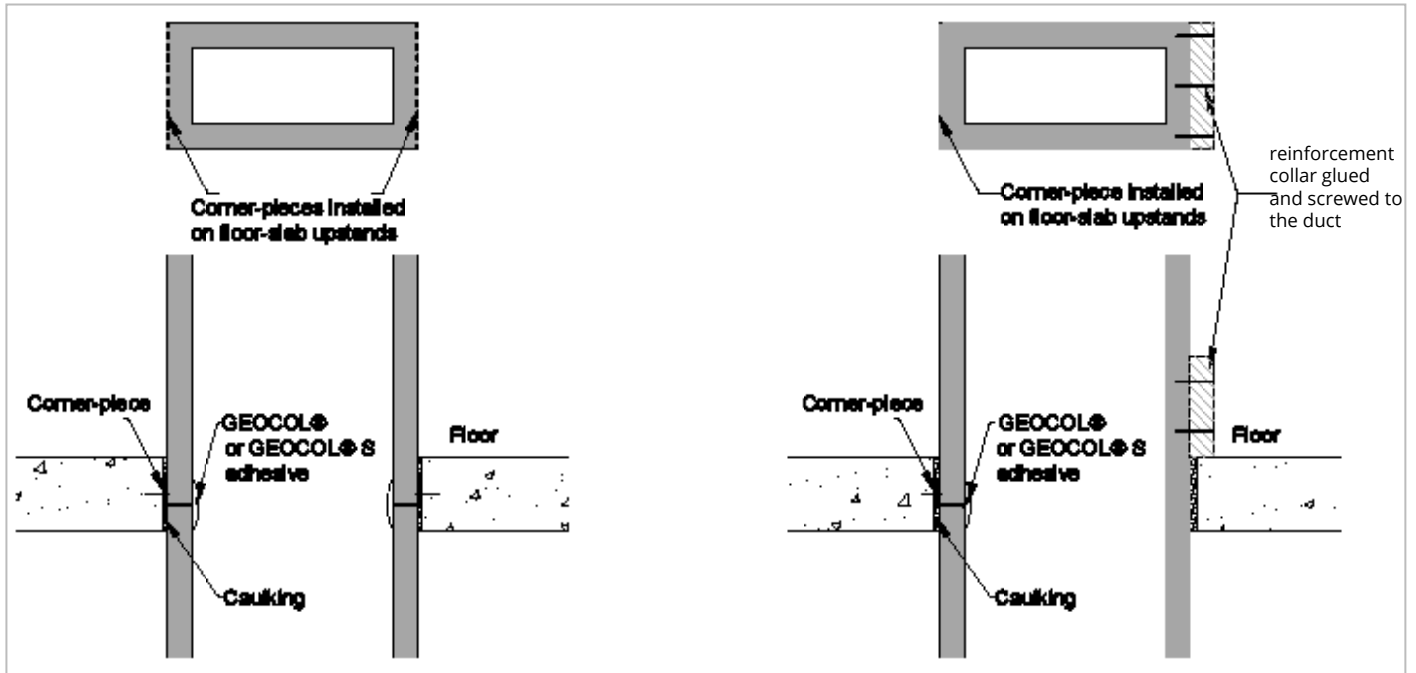

Support by 2 perpendicular reinforcement collars on the floor

Support by perpendicular 2 corner-pieces on the floor-slab upstands

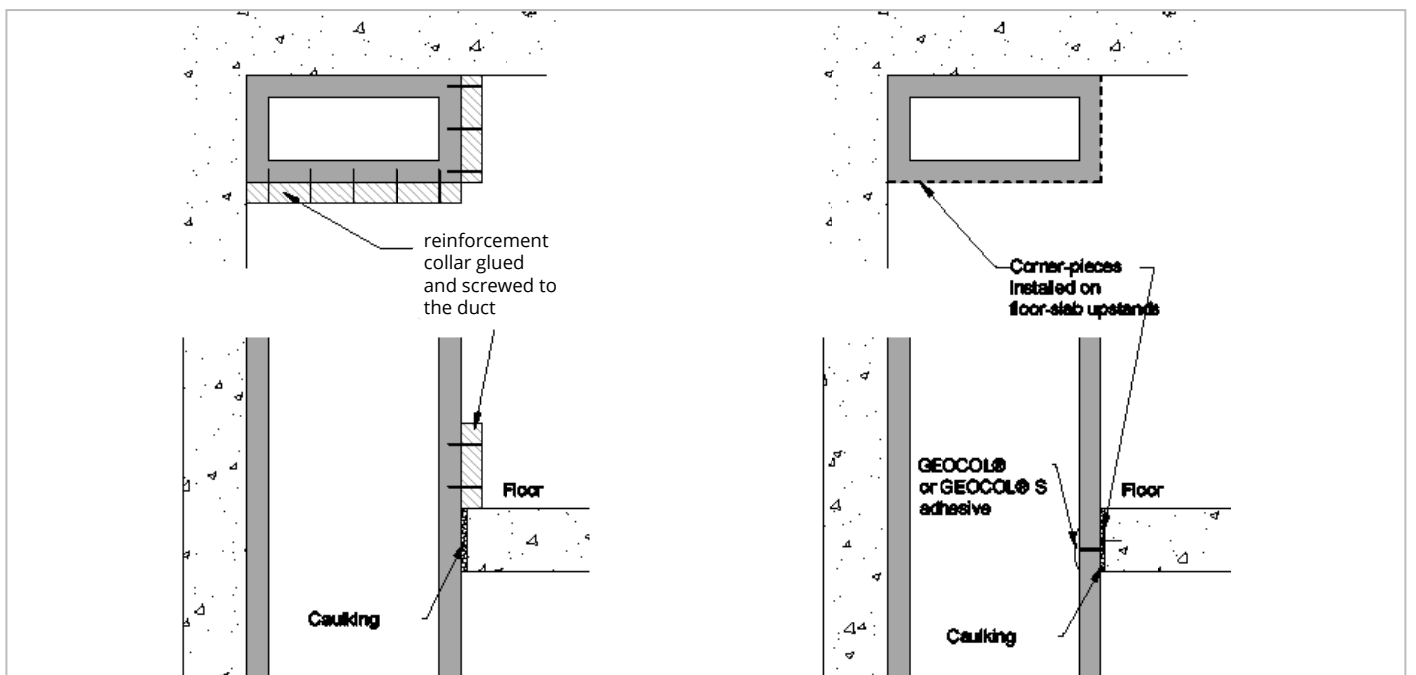

+ Other load-supporting principles are also available in extension 17/5 and 6 of documents EFR-16-002202 Rev. 1 and EFR-16-002203 Rev. 1.

VERTICAL SMOKE EXTRACTION AND VENTILATION DUCTS

Method of caulking a non-traversing vertical duct

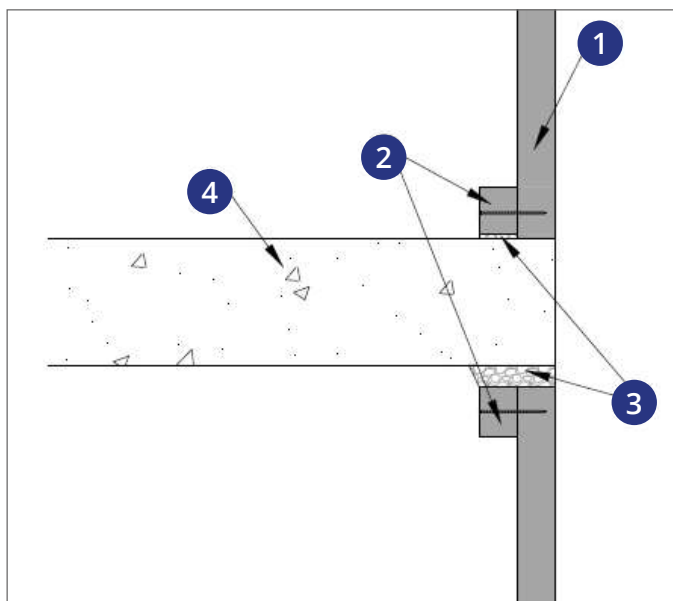

- 1 Vertical GEOTEC®S duct
- 2 GEOTEC®S reinforcement collars of 60 mm x duct thickness
- 3 GEOLCOL® adhesive (approx. 25 mm)
- 4 Horizontal wall

Other configurations

TAKE-OFF FROM A VERTICAL DUCT

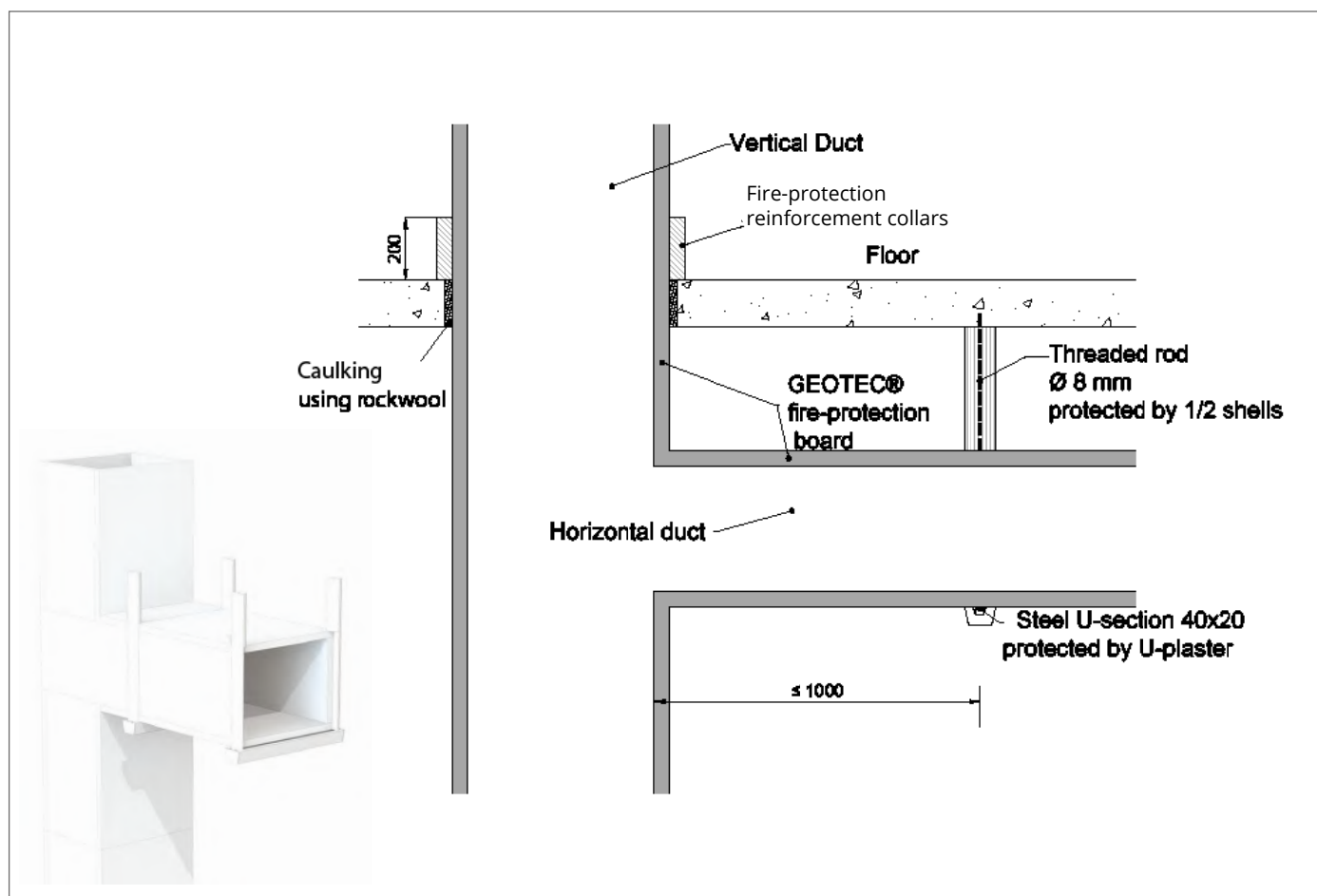

INSTALLING SMOKE EXTRACTION SHUTTERS

Description



Smoke extraction shutters are installed in horizontal and vertical GEOTEC® ducts to extract smoke in the event of a fire.

Manufacturer	Tunnel shutters	Gate shutters
RF-Technologies	EI 60 S to EI 120 S	EI 60 S to EI 120 S
Aldes		
Panol		
France Air		

E = Sealing against fire / I = Thermal insulation / S = Sealing against smoke

+ To install offset fire-break one-way shutters, please consult us.

Principle of installing a tunnel shutter in a GEOTEC® duct

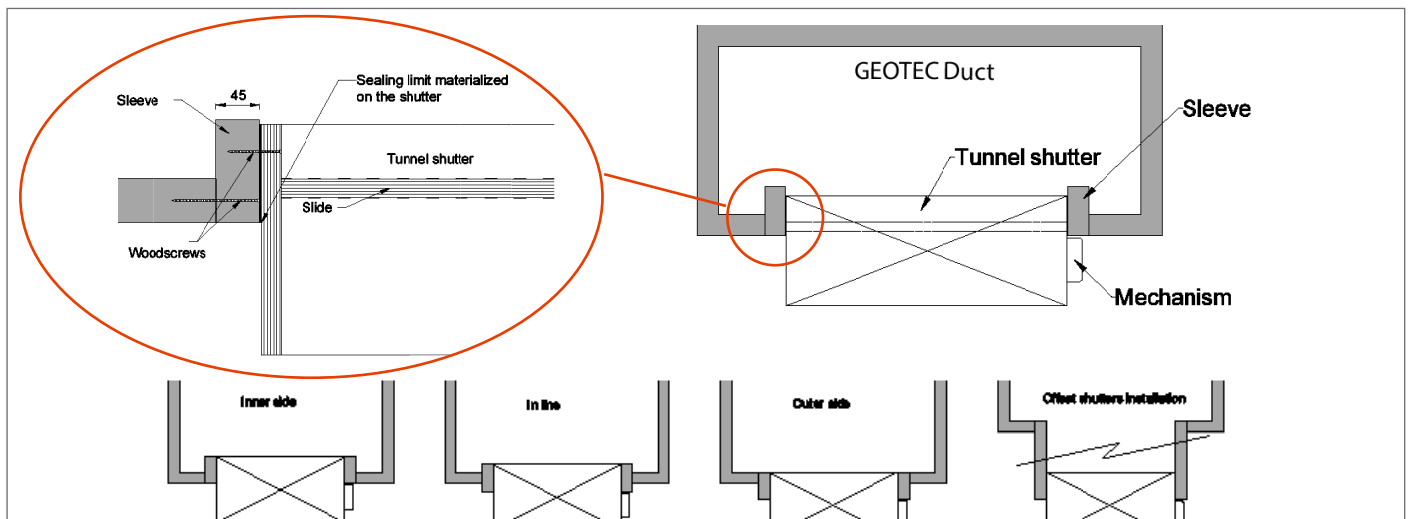

Principle of installing a gate shutter in a GEOTEC® duct

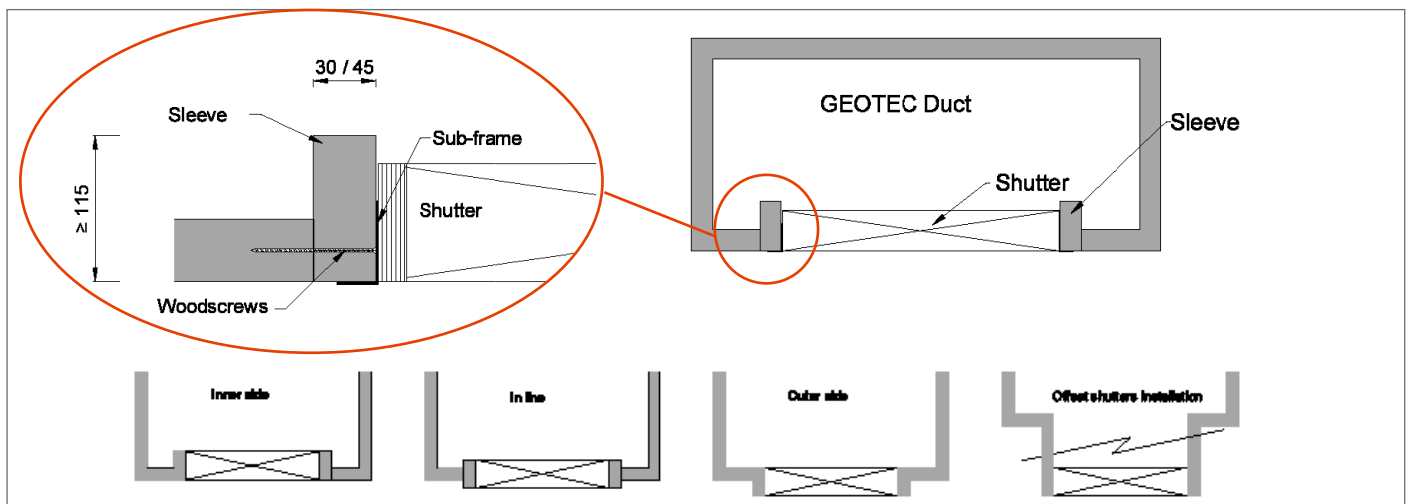

ADDITIONAL TECHNICAL DATA

■ Airflow performance

Hot sealing: Classification S in accordance with standards EN 1366-1 and 1366-8

i.e. a leakage flowrate per unit surface area of $<10 \text{ m}^3/\text{hr.m}^2$ for ventilation ducts and $< 5 \text{ m}^3/\text{hr.m}^2$ for smoke extraction ducts.

Cold sealing: Class D in accordance with standard EN 1507

Class	$\text{m}^3.\text{s}^{-1}.\text{m}^{-2}$	$\text{m}^3.\text{h}^{-1}.\text{m}^{-2}$
A	$0.027 \times p^{0.65} \times 10^{-3}$	$0.0972 \times p^{0.65}$
B	$0.009 \times p^{0.65} \times 10^{-3}$	$0.0324 \times p^{0.65}$
C	$0.003 \times p^{0.65} \times 10^{-3}$	$0.0108 \times p^{0.65}$
D	$0.001 \times p^{0.65} \times 10^{-3}$	$0.0036 \times p^{0.65}$

Loss of head

The GEOTEC® system also addresses the basic principles of air conditioning techniques with a roughness factor for untreated internal walls similar to that of steel ducts, i.e. $\epsilon = 0.05 \text{ mm}$ (for the smooth surface of the panel only).

■ Acoustic performance

Acoustic attenuation with lining

With the aim of restricting airborne noise propagated by the ducts and hence providing better acoustic performance, Geostaff proposes solutions for attaching a lining to the GEOTEC® ducts; the characteristics are listed in the table below:

Thickness GEOTEC® S	$R_w(C; C_{tr}) \text{ dB}$		
	1 BA13 + LdV 45 mm	2 BA13 + LdV 45 mm	3 BA13 + LdV 85 mm
30	49 (-3;-9)	53 (-2;-7)	57 (-1;-4)
45	50 (-2;-7)	54 (-1;-6)	60 (-1;-4)

■ Seismic performance

To guarantee that the GEOTEC® system works properly in seismically active zones or in buildings subject to significant vibration such as airports, stations or even underground car-parks, GEOTEC® ducts have been validated in accordance with the S2 set of spectra at 5% damping as per standard CRT 91 C 112 00. Carried out by the SOPEMEA laboratory (RE 1E31169ME), these calculations showed the excellent resistance to seismic activity and vibration of the GEOTEC® system.

■ Performance under damp conditions

Where ventilation or smoke extraction ducts are constructed in rooms where the humidity is high, we propose that our products be treated with a water repellent. This treatment is applied to the bulk of the material, and does not alter the fire resistant properties of the products in any way.



ASSESSMENTS

GEOTEC® S

Tests in accordance with EN 1366-5	Thickness (mm)	EFFECTIS classification documents	Internal cross-sections (mm)	EI S i o	Max ht
Protection of horizontal and vertical service ducts	30	Cert. EFR-16-003067 Rev. 1	50x50 to 2500x1500	60	7 m (2 reinforcement collars) 10 m (3 reinforcement collars)
	45			120	

E = Sealing against fire / I = Thermal insulation / i <-> o = internal or external fire

NB: A certificate exists also for fibre rope versions:
Cert. EFR-16-003069 Rev. 1

Extensions to EFR-16-003067 Rev. 1

Extension 17/6	<i>Various support principles for horizontal service ducts</i>
Extension 17/5	<i>Various load-carrying principles for vertical service ducts</i>
Extension 16/3	<i>Expansion joint treatment for GEOTEC® service ducts</i>
Extension 17/4	<i>Assembling GEOTEC® conduits using staples</i>
Extension 17/5	<i>Construction of EI 240 service ducts (Installation using polochons* only)</i>

**polochons : mixture of sisal fibers and bonding plaster*

Laboratory Appraisals

APL EFR-16-003921	<i>Protection for 2 and 3 face service ducts (50x50 to 2500x1500mm int.)</i>
APL EFR-17-001582	<i>Protection for non-traversing service ducts (horiz. and vert.)</i>
APL EFR-18-003855	<i>Protection for single face service ducts</i>

GEOFLAM® C Light

Tests in accordance with EN 1366-5	Thickness (mm)	EFFECTIS classification documents	Internal cross-sections (mm)	EI S i ↔ o	Max ht
Protection of horizontal and vertical service ducts	35	Doc. EFR-14-001050 Rev. 1	50x50 to 1250x1000	120	7 m (2 reinforcement collars) 10 m (3 reinforcement collars)

E = Sealing against fire / I = Thermal insulation / i ↔ o = internal or external fire

Extensions to EFR-14-001050 Rev. 1

Extension EFR-15-000916	<i>Various support principles for horizontal service ducts</i>
Extension EFR-14-001632 Rev. 1	<i>Various load-carrying principles for vertical service ducts</i>
Extension EFR-14-003038	<i>Expansion joint treatment for GEOFLAM® service ducts</i>
Extension 17/9	<i>Construction of EI 240 service ducts (4 hr fire-break)</i>

Laboratory Appraisals

APL EFR-14-001478 Rev. 2	<i>Protection for 2 and 3 face service ducts (50x50 to 2500x1500mm int.)</i>
APL EFR-19-XXXXXX (pending)	<i>Protection for non-traversing service ducts (horiz. and vert.)</i>

SYSTEM OVERVIEW

The protection service ducts, classified in accordance with standard EN 13501-2, protects service ducts carrying gas, medical fluids, miscellaneous pipework or even electrical cable trays for up to 2 hours exposure to fire (EI 120). For choice, they can be implemented as follows:

- using GEOTEC®S boards in the same way as for ducts (see page 23 and 29);
- using GEOFLAM®C Light channels for sections up to 350 x 200 mm (see page 12).

■ Certificates: fire resistance classification report

All our systems are subjected to tests carried out by official institutions. The reports on these tests form the basis of the certification of our protection systems for service ducts and shafts.

- Classification in accordance with EN 13501-1 and EN 13501-2
- CE Certification (in accordance with EAD 350142-00-1106)

HORIZONTAL SYSTEM

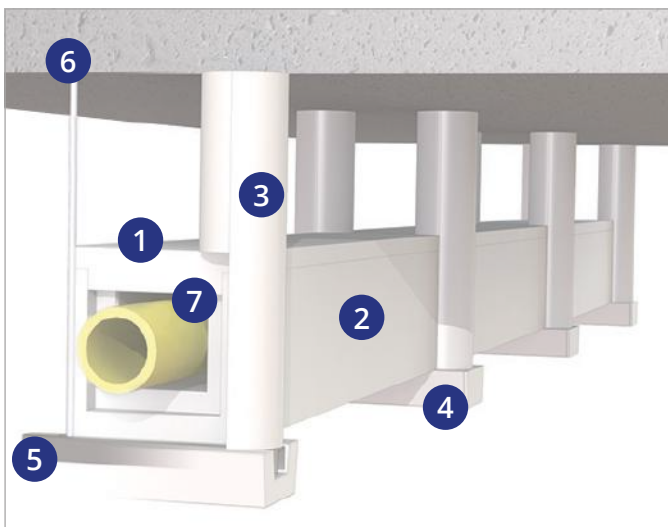

- 1 GEOTEC®S boards or GEOFLAM®C Light covers
- 2 GEOTEC®S boards or GEOFLAM®C Light channels
- 3 GEOTEC®A 1/2 shells
- 4 GEOTEC®A U-plaster element
- 5 **Steel U-section and Ø 8 nut**
- 6 **Ø8 pin and threaded rod**
- 7 GEOCOL® or GEOCOL®S adhesive

■ New

In accordance with extension 17/10 of doc. EFR-14-A-001050 Rev. 1, GEOFLAM®C Light

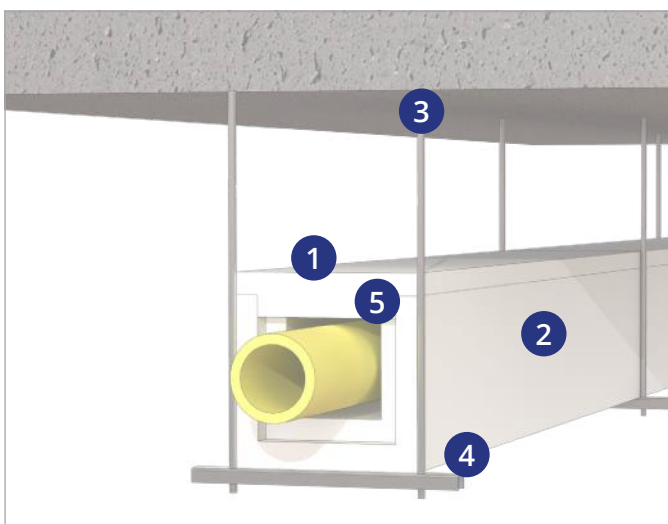

- 1 GEOFLAM®C Light covers
- 2 GEOFLAM®C Light channels
- 3 **Ø12 pin and threaded rod**
- 4 **Steel U-section 41x41 and Ø 12 nut**
- 5 GEOCOL® adhesive

HORIZONTAL SYSTEM

■ STEPS FOR INSTALLING A HORIZONTAL SERVICE DUCT (USING GEOFLAM® C LIGHT CHANNELS)

Installation with a protection for metal supports



- Mark out every 1000 mm
- Drill Ø10 holes
- Install Ø8 pins
- Screw up the Ø8 threaded rods



- Drill the galvanised steel U-sections 25x25x25x2
- Place the steel U-sections every 1000 mm



- Position the channel



- Glue the rebates on the channel and cover
- Put the cover in place



- Pre-glue and place the protective U-plaster elements against the underside of the channel



- Pre-glue and place the 1/2 shells to protect the threaded rods



- Re-start from step 3
- Glue and fit together with the previous channel

OTHER HORIZONTAL CONFIGURATIONS

INSTALLING ON BRACKETS

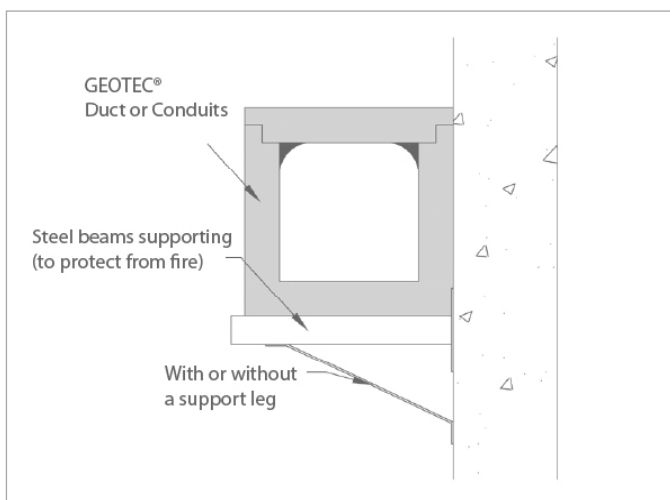
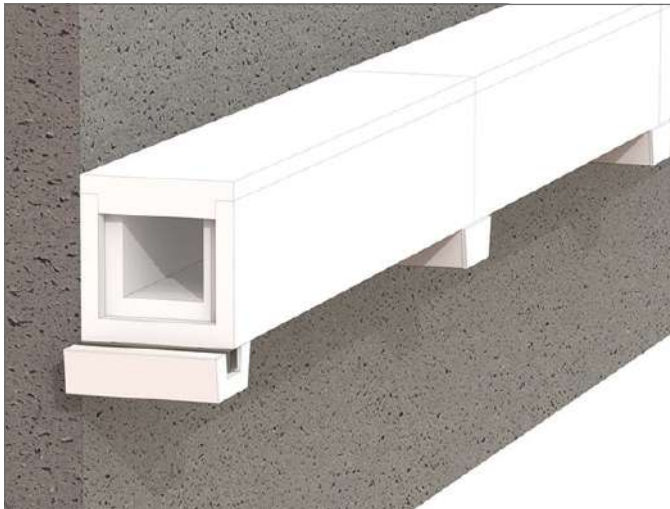

FEATHERED PLACEMENT

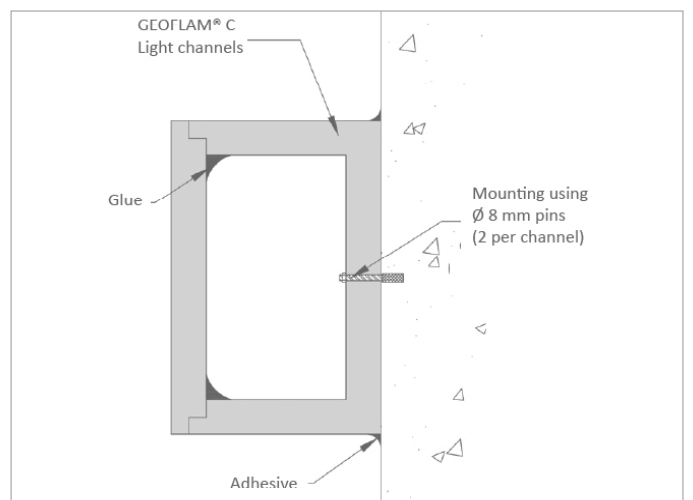

+ Other support principles are also available in extension 17/6 OF DOC. EFR-16-003067 Rev 1

SHROUDING OF VERTICAL SERVICE CONDUITS



- 1 GEOTECH®S boards or GEOFLAM®C Light channels
- 2 GEOTECH®A reinforcement collar
- 3 GEOCOL® or GEOCOL®S adhesive

+ Other support principles are also available in extension 17/5 of doc. EFR-16-003067 Rev. 1

VERTICAL SYSTEM

STEPS FOR INSTALLING A VERTICAL SERVICE DUCT (USING GEOFLAM® C LIGHT CHANNELS)

1

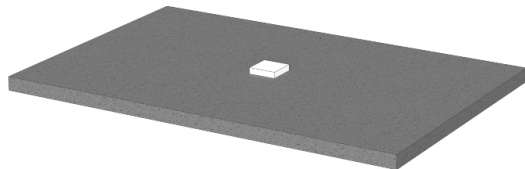

L.C.*

- Placing the 1st board on the ground

2

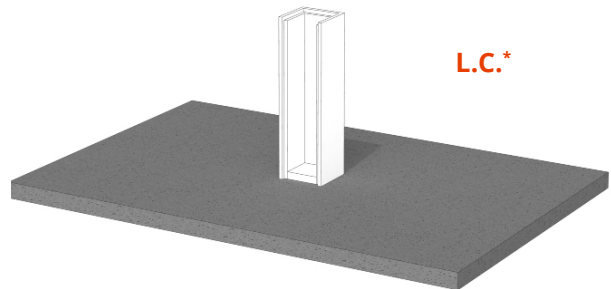

L.C.*

- Glue the board and side rebates of the channel to the floor
- Put the channel vertically in place

3

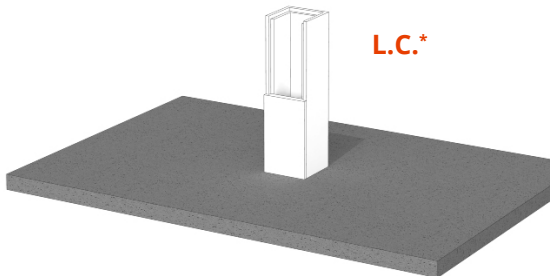

L.C.*

- Cut the first cover in two to create a joint offset
- Glue the cover rebates
- Place it vertically

4

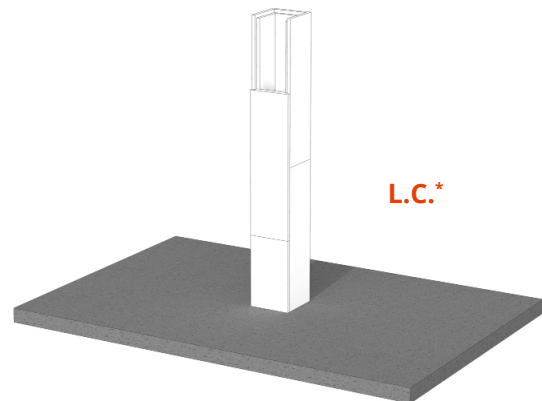

L.C.*

- Recommence at step 2
- Glue and fit together with the previous sections

5

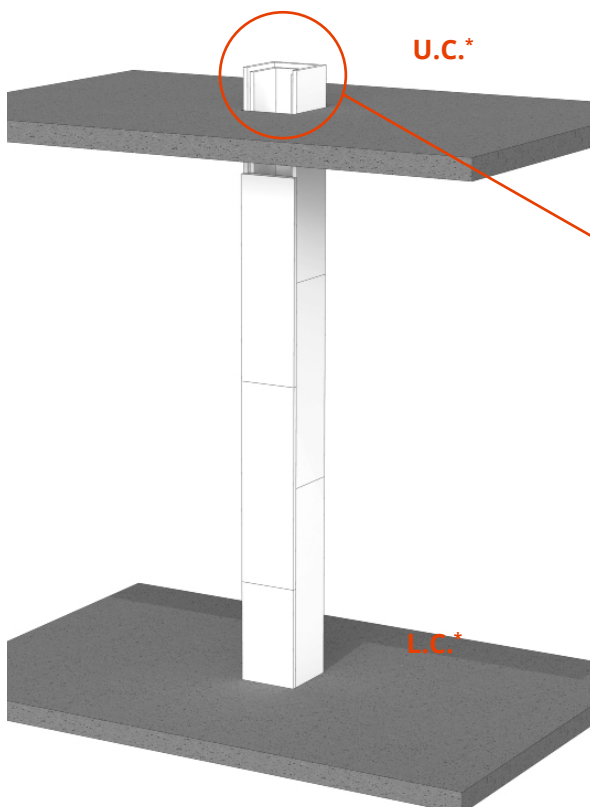

U.C.*

L.C.*

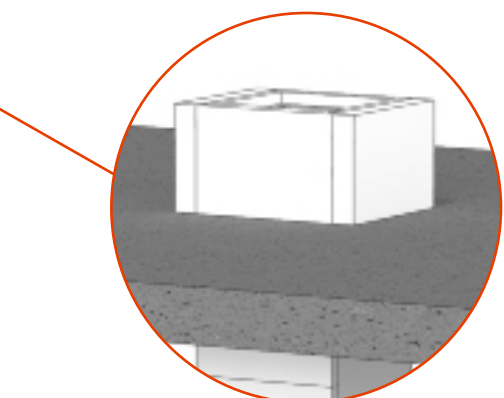

- Where the horizontal partition crosses, apply caulking using polyurethane foam or rockwool (26 kg/m³ minimum)
- Put the reinforcement collars in place by gluing both sides of the channel bearing on the floor (Max height between load supports 7 m)

*L.C.: Lower ceiling - U.C.: Upper ceiling

FIRE PROTECTION OF SERVICE DUCTS AND SHAFTS WITH 2 OR 3 FACES

The range of protection for service ducts also provide protection on 2 or 3 faces, in accordance with the Laboratory Appraisal EFR-16-003921 and EFR-14-001478 Rev. 2; the concrete support structure stands in for the missing face(s).

HORIZONTAL INSTALLATION

2 face service duct protection

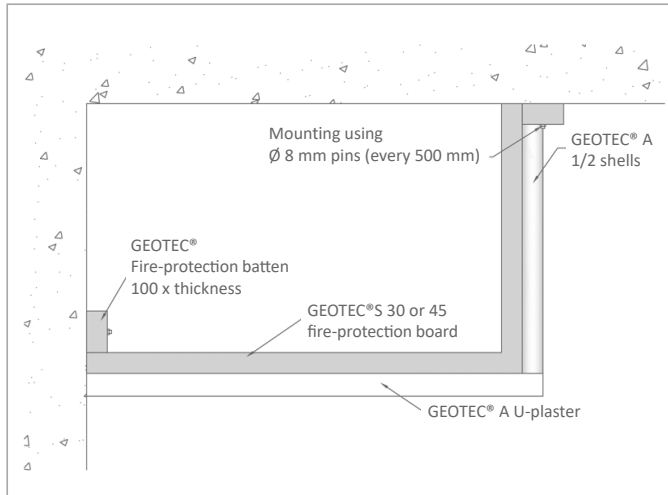

3 face service duct protection

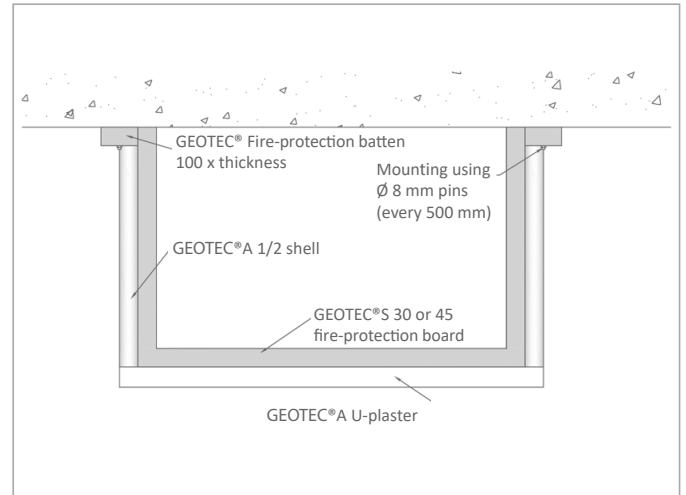

VERTICAL INSTALLATION

2 face service duct protection

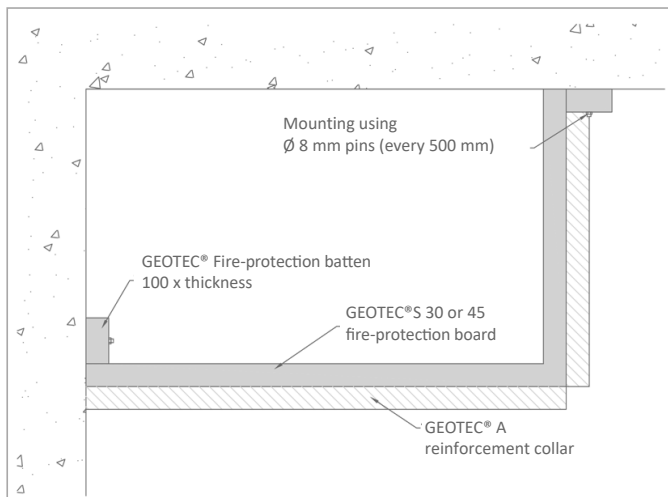

3 face service duct protection

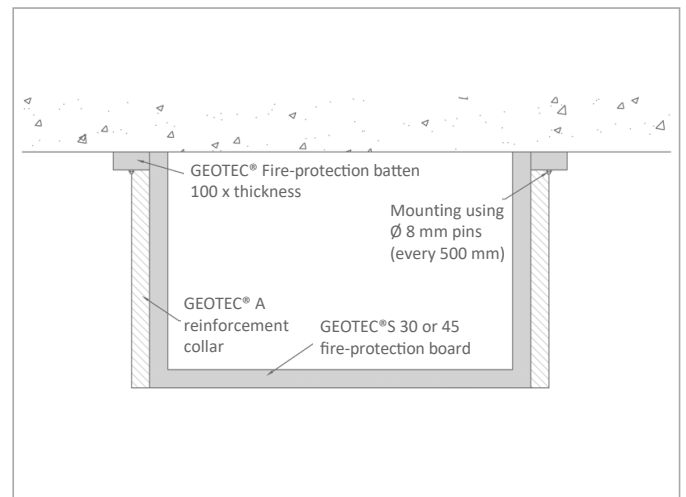

+ GEOTEC® battens may be placed anywhere inside or outside the service duct protection.



SYSTEM OVERVIEW

The fire stability of reinforced concrete structures and substrates is obtained by restricting the temperature rise in the steelwork within the concrete.

If the existing load-bearing structures need to be strengthened (in the case of a change of use, anti-seismic confinement, refurbishment, etc.), one solution involves bonding carbon fibre reinforced plates with an epoxy resin adhesive. époxydique.

With the aim of guaranteeing the strength and performance of these carbon reinforcements in the event of fire, the solution has to guarantee a temperature of the adhesive used.

This maximum temperature, varying between 45 and 80° C, appears in the technical notes of the manufacturers to whom the reader should refer.

Following the fire resistance tests carried out at the Efectis laboratory, and via the intermediary of Laboratory Appraisal EFR-18-001644, GEOSTAFF® proposes validated solutions using GEOTEC®S to protect the carbon fibre reinforcements installed under the floor slab and concrete beam, depending on the desired levels of fire performance and the critical temperatures provided by the manufacturer.

Protection under concrete floor slab

Desired interface temperature (°C)	GEOTEC®S PROTECTIVE THICKNESS				
	Desired fire performance				
	30 min	60 min	90 min	120 min	180 min
45	2x30 mm (Overlap 100 mm)	2x45 mm (Overlap 100 mm)	2x45 mm (Overlap 350 mm)	3x45 mm (Overlap 200 mm)	-
60	2x30 mm (Overlap 100 mm)	2x30 mm (Overlap 100 mm)	2x45 mm (Overlap 100 mm)	2x45 mm (Overlap 200 mm)	-
80	2x30 mm (Overlap 100 mm)	2x30 mm (Overlap 100 mm)	2x30 mm (Overlap 100 mm)	2x45 mm (Overlap 100 mm)	2x45 mm (Overlap 100 mm)

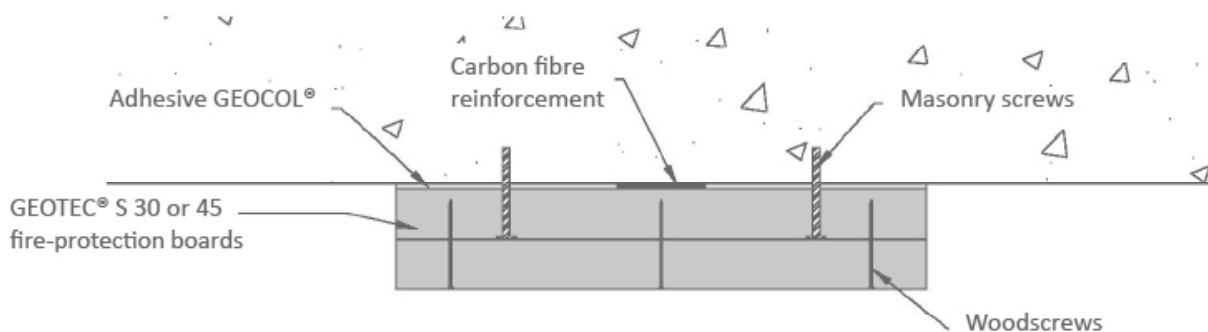

*In some cases, a third thickness may be deemed necessary.

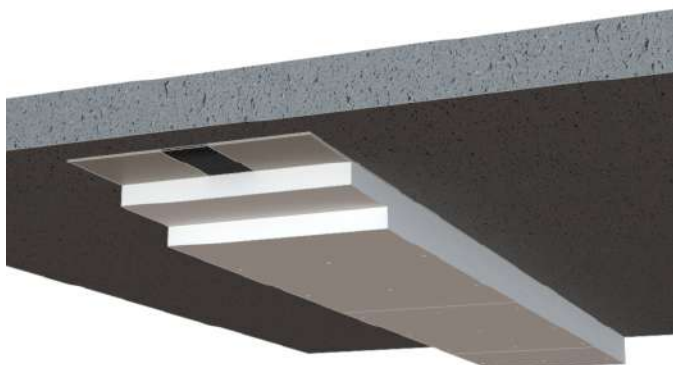

In this configuration, GEOCOL® adhesive is applied around the periphery of the carbon fibre reinforcement. A first protective thickness using GEOTEC®S is attached to the concrete using masonry screws 400 mm apart in both directions. The second thickness is attached to the first via offset joints, using woodscrews 200 mm apart in both directions.

To facilitate the installation, glue points can also be applied when laying the second and third board thickness.

PROTECTION FOR CARBON FIBRE BONDED BEAMS

Protection under the beam

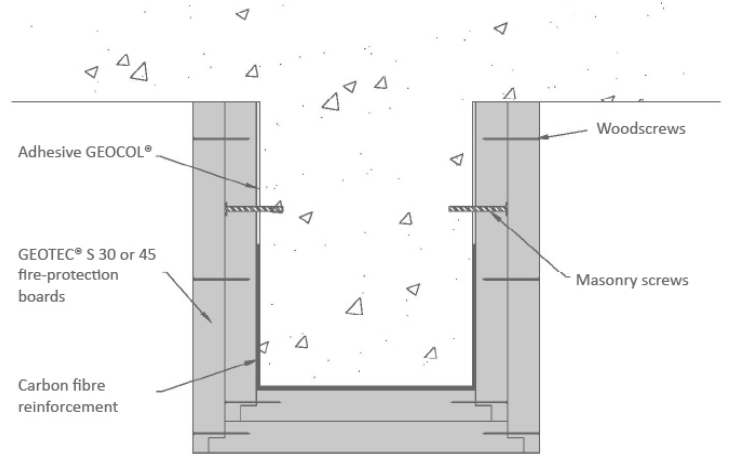

In this configuration, the beam is clad on three sides. GEOCOL® adhesive is applied around the periphery of the carbon fibre reinforcement.

The first protective thickness of GEOTEC®S is attached between the vertical surfaces using masonry screws 400 mm apart. The third surface, corresponding to the bottom of the beam, is attached to the panels previously held in place with woodscrews 200 mm apart. The second thickness is attached to the first via offset joints, using woodscrews 200 mm apart in both directions.

To facilitate the installation, glue points can also be applied when laying the second and third board thickness.

■ Reinforcement installed on the bottom of the beam

Desired interface temperature (°C)	GEOTEC®S PROTECTIVE THICKNESS			
	Desired fire performance			
	30 min	60 min	90 min	120 min
45	2x45 mm	2x45 mm	3x45 mm	-
60	2x45 mm	2x45 mm	2x45 mm + 30 mm	3x45 mm
80	2x30 mm	2x45 mm	2x45 mm	2x45 mm

■ Reinforcement installed on the side of the beam

Desired interface temperature (°C)	GEOTEC®S PROTECTIVE THICKNESS			
	Desired fire performance			
	30 min	60 min	90 min	120 min
45	2x45 mm	2x45 mm	2x45 mm + 30 mm	3x45 mm
60	2x30 mm	2x45 mm	2x45 mm	2x45 mm + 30 mm
80	2x30 mm	2x30 mm	2x45 mm	2x45 mm

PROTECTION FOR CARBON FIBRE BONDED BEAMS





Dimensions

EI i↔o	Dimensions of the door (opening)	Free way	Overall dimensions	Total Thickness
	E x F	C x D	A x B	G
60	200 x 200 up to	162 x 162 up to	294 x 294 up to	72,5
120	600 x 600	562 x 562	694 x 694	87,5

DOCUMENTATION nr. EFR-19-002200

The inspection hatches are tested with an indifferent direction of fire

Product description

GEOSYSTEM® V60 & V120 inspection hatches consist of a frame made of fire-resistant plasterboard and two successive leaves.

The first leaf, which acts as an aesthetic covering, is opened/closed by simply pressing on the hatch, while the second, which can be removed, is equipped with two steel pins to remove it.

Applications

Easy to install and in compliance with current standards, **GEOSYSTEM® V60 & V120** inspection hatches, with fire resistance ratings EI 60 and EI 120 (FP1H and 2H), can be installed in technical ducts, solid walls or as passage openings in partition walls.

Usage

The inspection hatches **GEOSYSTEM® V60 & V120** can be installed :

- **GEOTEC®** and **GEOFLAM®** protection of service ducts and shafts
- Solid walls
- Partitions or false walls
- Plasterboards walls

Transportation and storage

Transport and store on a flat, protected surface. Keep away from water.

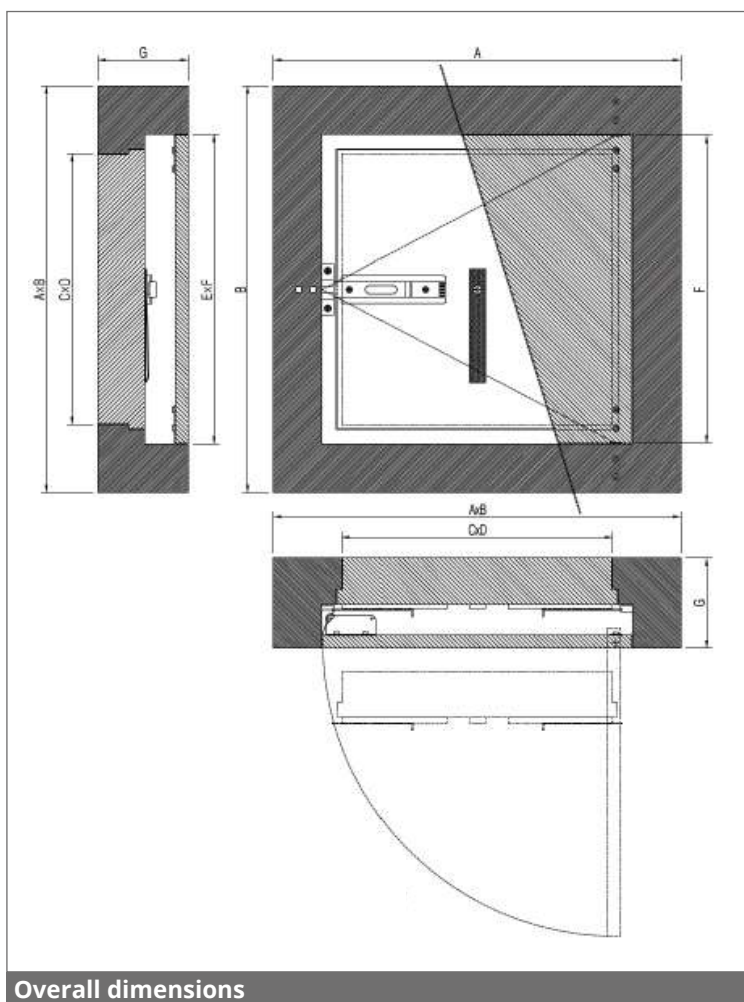

Overall dimensions

■ **Certificates: fire resistance classification report**

Tests in accordance with EN 1634-1	EFFECTIS classification documents	Dimensions (mm)	EI	
			60	120
EI 60 hatch	Document n° EFR-19-002200	200 x 200 up to 600 x 600	x	
EI 120 hatch				x

E = Fire sealing / I = Thermal insulation

⇒ **Please consult us if you require fire-protection hatches installed horizontally**

■ **Assembly of GEOSYSTEM® inspection hatches inside a GEOTEC® technical duct**

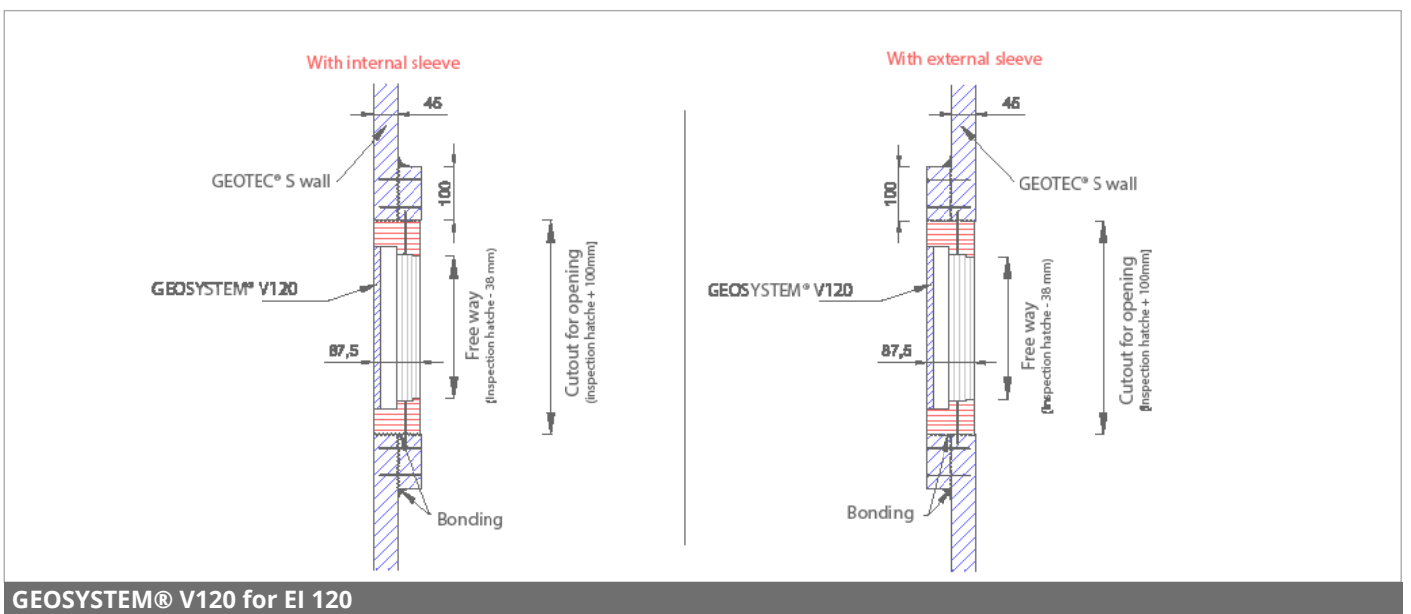
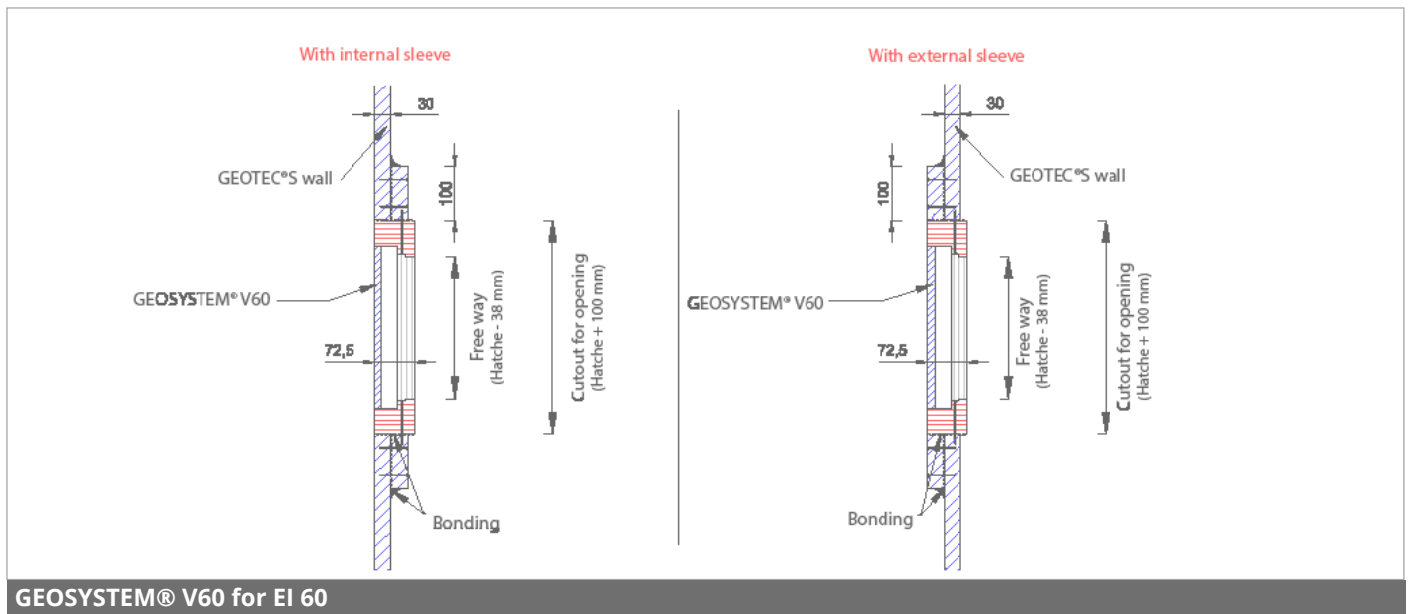

GEOSYSTEM V60 & V120 - FP Inspection hatches

- Assembly of GEOSYSTEM® inspection hatches inside a plasterboards wall

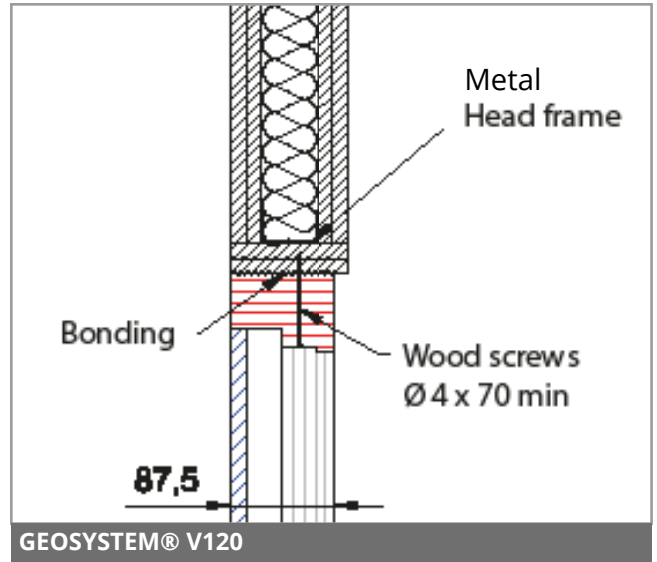
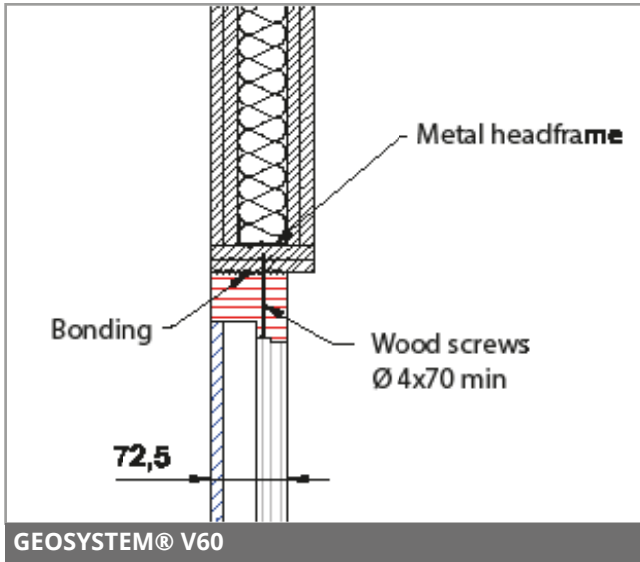

- Assembly of GEOSYSTEM® inspection hatches inside a false wall

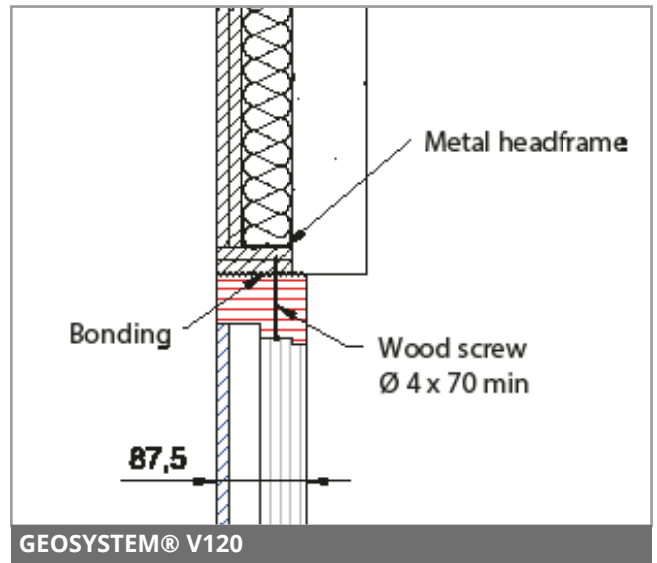
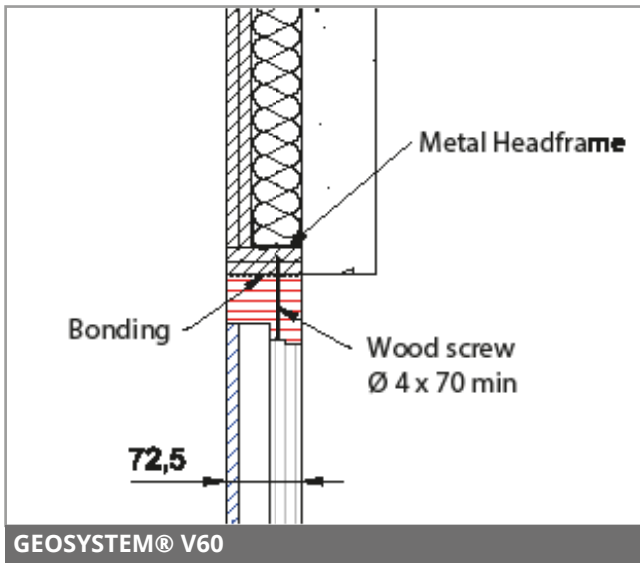

GEOSYSTEM V60 & V120 - FP Inspection hatches

- Assembly of GEOSYSTEM® inspection hatches inside a cellular concrete wall or a plasterboards wall

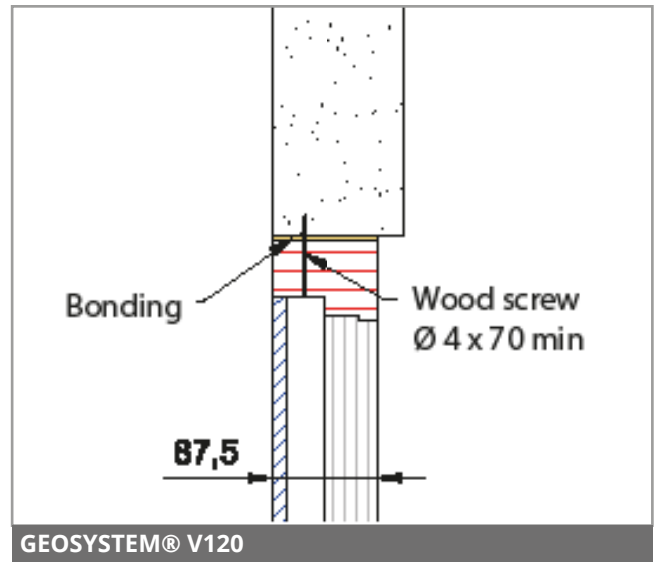
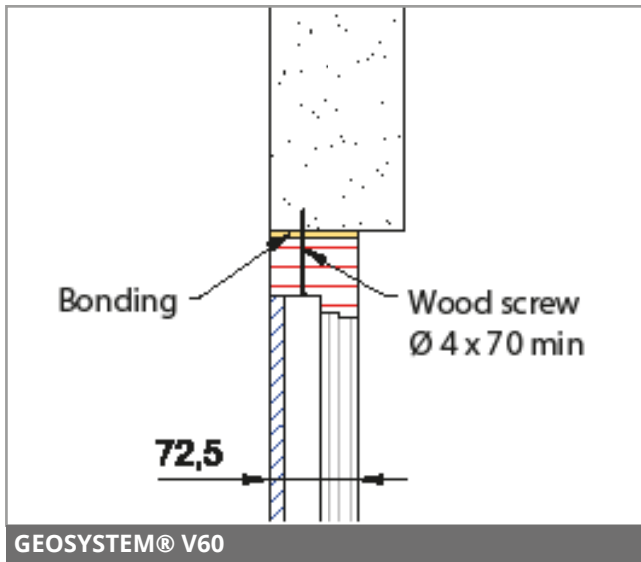

- Assembly of GEOSYSTEM® inspection hatches inside a solid wall

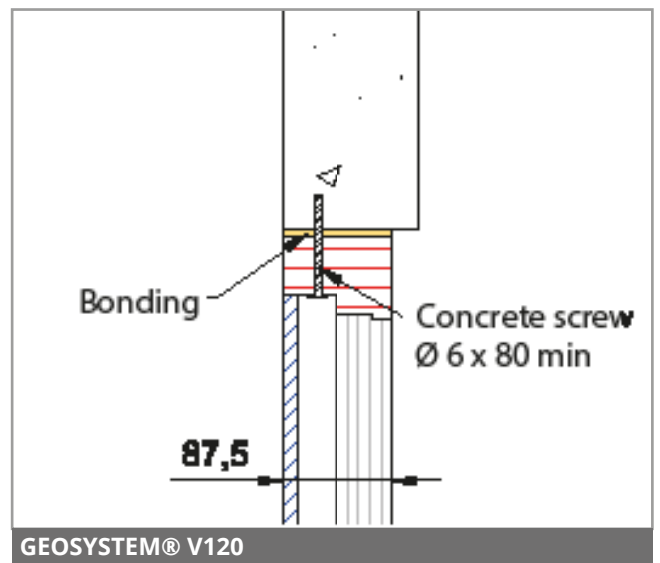
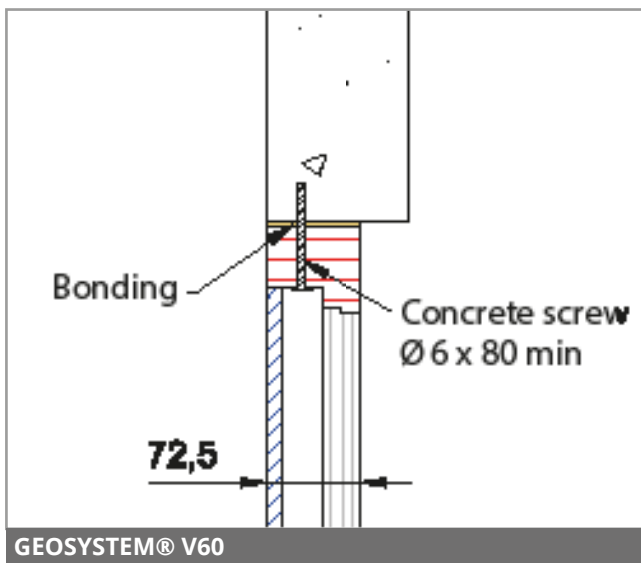



Dimensions

EI (mm)	Dimensions of the door	Thickness of the frame	Width of the frame	Thickness or height of the latch	Total Thickness
	AxB (mm)	C	D	E	Z
60	200 x 200 up to	30	55	-	45
120	1500 x 1000	50	55	30	80

Hatches of special dimensions may be constructed.

Product description

The inspection hatch consists of two aluminium profile frames (1 fixed and 1 opening) and finished off with plasterboard.

The two frames of the inspection hatch comprise four aluminium profiles attached rigidly to one another by means of a special welding technique.

An intumescent seal is placed around the periphery of the door and the fixed frame.

The hatch is fitted with two locking systems (cable and snap-hook).

For safety, these systems must always be hooked up before closing the door panel. The invisible spring closures allow opening and closing by a simple pressure on the hatch.

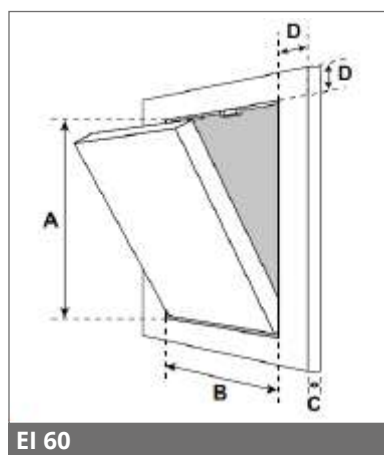

EI 60

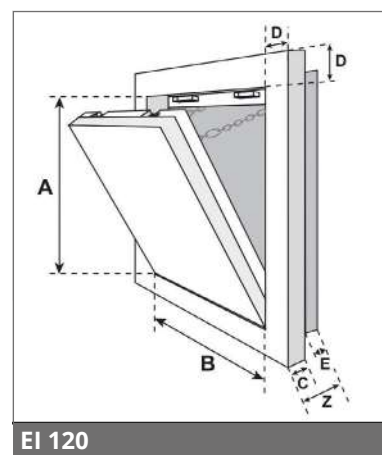

EI 120

Applications

The **GEOSTAFF®** inspection hatches must be installed vertically in order to access the service ducts and shafts (Document 12-A-119 Rev.1 & Extensions 15/2 and 15/3). With a fire-protection time of EI 60 and 120 (1 hour and 2 hour fire-protection), our inspection hatches can be installed on our **GEOTEC®** and **GEOFLAM®** products.

Usage

Installed in protective systems for service ducts and shafts, **GEOTEC®** and **GEOFLAM®**.

Transportation and storage

Transport and store on a flat, protected surface. Keep away from water.

AVAILABLE LOCKS (ONLY IN EI 60)



Turn-key



Cylinder lock



Deadlock

■ **Certificates: fire resistance classification report**

Tests in accordance with EN 1634-1	EFFECTIS classification documents	Dimensions (mm)	EI	
			60	120
EI 120 hatch	Document 12-A119 Rev.1 + Ext. 15/3	200 x 200 à 1500 x 1000		x
EI 60 hatch	Ext. 15/2		x	

E = Fire sealing / I = Thermal insulation

■ **Illustrative diagram**

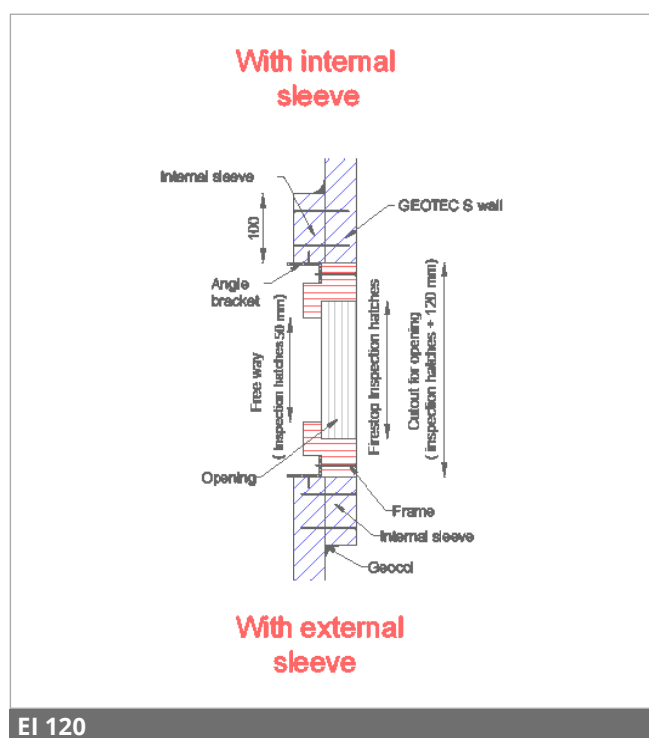
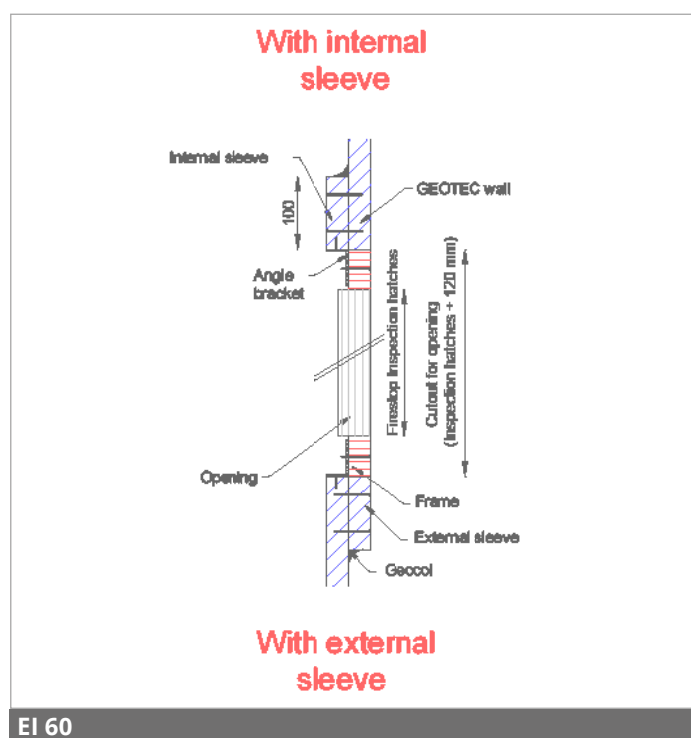

⇒ Please consult us if you require fire-protection hatches installed horizontally

Fire-protection ventilation grille



Dimensions

Thickness (mm)	EI (mm)	Dimensions (w x h) (mm)	Weight (kg)
50	120*	95 x 95	0.3

E = Fire sealing / I = Thermal insulation

* In accordance with extension EFR-14-003037 of docs. 12-A-698 Rev.1 and EFR-14-A-001050 Rev.1

Product description

Square **GEOFLAM®G** fire-protection ventilation grilles can be installed in the **GEOFLAM®** protective systems for horizontal and vertical service conduits, to avoid heating of electrical cables for example when protecting a cable tray. These grilles are made of plastic profiles filled with bands of intumescent material. These provide fire resistance up to EI 120.

Advantages

- Approved for installation on **GEOFLAM®** protective ducts
- Maintenance free
- Easy to install

Storage and handling

For safety's sake, these grilles should be stored and handled with care.

Caution:

- AVOID ANY DAMAGE
- AVOID CONTACT WITH WATER
- KEEP AWAY FROM HEAT

Maintenance and cleaning

Clean with a soft dry cloth.

Do not use abrasive sponges, alkaline or acid detergents, or volatile solvents such as alcohol or other solvent-based products. Use of such products may damage the grille.

Installation

- The grille can be installed with its slats horizontal
- Installation must comply with extension EFR-14-003037
- Fire-protection grilles cannot be used for forced-air ventilation.

Characteristics of a fire-protection ventilation grille

Description	Fire-protection ventilation grille
Operation	The slats begin to react over 100°C
Operating pressure	-5 to +10 Pa
Safety position	Horizontal slats
Direction of air circulation	Any
Fire-side	Any
Temperature of usage	Max. 60 °C
Environment	For internal use
Maintenance	Maintenance free
Acidity	pH 8.91





HEAD OFFICE

ZAC du Chêne Bocquet
 6 bis, rue Jacques Kellner
 95150 TAVERNY
 Tel: +33(0)1 30 26 37 00
 Fax: +33(0)1 39 95 96 23

Opening hours

Monday to Thursday:
 9:00 - 12:30 / 13:30 - 18:00
 Friday:
 9:00 - 12:30 / 13:30 - 17:00

Contact us

com@geostaff.fr

GEOSTAFF FACTORY

Rue de St-Just
 60130 Catillon-Fumechon
 It may be possible to pick up
 some of our products from this
 address. Please contact us for
 further information.

SALES DEPARTMENT

Geostaff IDF

+33(0)7 78 07 33 89

Geostaff Grand Est

+33(0)7 76 08 75 54

Geostaff Grand Ouest

+33(0)7 77 41 87 65

Geostaff Déco PACA

+33(0)6 80 72 09 85

LOGISTICS DEPARTMENT

ZAC du Chêne Bocquet
 6 bis, rue Jacques Kellner
 95150 TAVERNY
 Tel: +33(0)1 30 26 36 90

Opening hours

Open from Monday to
 Thursday: 6:30 - 17:00
 Friday: 6:30 - 12:30

Contact us

com@geostaff.fr

For ease of collection in **the South of France**, there is a GEOSTAFF warehouse at ZAC LA GRAVE 06150 CARROS (Alpes-Maritimes).

Please contact us for further information.

HEAD OFFICE

6 bis, rue Jacques Kellner • 95150 TAVERNY - FRANCE
Tel. +33 (0)1 30 26 37 00 • Fax +33 (0)1 39 95 96 23 • com@geostaff.fr

WWW.GEOSTAFF.EN