

European Technical Assessment

ETA 15/0653
Version 01
Date of issue: 2015-12-08



UBAtc Assessment Operator:
Belgian Construction Certification
Association
Rue d'Arlon 53 - 1040 Brussels
www.bcca.be - info@bcca.be



Technical Assessment Body issuing the European Technical Assessment: UBAtc.
UBAtc has been designated according to Article 29 of Regulation (EU) No 305/2011
and is member of EOTA (European Organisation for Technical Assessment)

Trade name of the construction product:

GEOFLAM® F Light

Product family to which the construction product belongs:

35 - Fire Protective board

Manufacturer:

GEOSTAFF
rue de Montigny 19
95100 Argenteuil
France

Manufacturing plant(s):

01

Website:

www.geostaff.fr

This European Technical Assessment is issued in accordance with Regulation (EU) No 305/2011, on the basis of:

Guideline for European technical approval (ETAG), used as European Assessment Document (EAD): 018-1 and 018-4

This European Technical Assessment contains:

28 pages, including 3 annexes which form an integral part of the document.



**European Organisation
for Technical Assessment**

Legal bases and general conditions

- 1 This European Technical Assessment is issued by UBAtc (Union belge pour l'Agrément technique de la construction, i.e. Belgian Union for technical Approval in construction), in accordance with:
 - Regulation (EU) No 305/2011¹ of the European Parliament and of the Council of 9 March 2011 laying down harmonised conditions for the marketing of construction products and repealing Council Directive 89/106/EEC
 - Commission Implementing Regulation (EU) No 1062/2013² of 30 October 2013 on the format of the European Technical Assessment for construction products
 - European Assessment Document (EAD) :
 - Guideline for European technical approval (ETAG), used as European Assessment Document (EAD): ETAG 018-4
- 2 Under the provisions of Regulation (EU) No 305/2011, UBAtc is not authorized to check whether the provisions of this European Technical Assessment are met once the ETA has been issued.
- 3 The responsibility for the conformity of the performances of the products with this European Technical Assessment and the suitability of the products for the intended use remains with the holder of the European Technical Assessment.
- 4 Depending on the applicable Assessment and verification of constancy of performance (AVCP) system, (a) notified body(ies) may carry out third-party tasks in the process of assessment and verification of constancy of performance under this Regulation once the European Technical Assessment has been issued.
- 5 This European Technical Assessment allows the manufacturer of the construction product covered by this ETA to draw up a declaration of performance for the construction product.
- 6 CE marking should be affixed to all construction products for which the manufacturer has drawn up a declaration of performance.
- 7 This European Technical Assessment is not to be transferred to other manufacturers, agents of manufacturers, or manufacturing plants other than those indicated on page 1 of this European Technical Assessment.
- 8 The European Technical Assessment holder confirms to guarantee that the product(-s) to which this assessment relates, is/are produced and marketed in accordance with and comply with all applicable legal and regulatory provisions, including, without limitation, national and European legislation on the safety of products and services. The ETA-holder shall notify the UBAtc immediately in writing of any circumstance affecting the aforementioned guarantee. This assessment is issued under the condition that the aforementioned guarantee by the ETA-holder will be continuously observed.
- 9 According to Article 11(6) of Regulation (EU) No 305/2011, when making a construction product available on the market, the manufacturer shall ensure that the product is accompanied by instructions and safety information in a language determined by the Member State concerned which can be easily understood by users. These instructions and safety information should fully correspond with the technical information about the product and its intended use which the manufacturer has submitted to the responsible Technical Assessment Body for the issuing of the European Technical Assessment.
- 10 Pursuant to Article 11(3) of Regulation (EU) No 305/2011, manufacturers shall adequately take into account changes in the product-type and in the applicable harmonised technical specifications. Therefore, when the contents of the issued European Technical Assessment do not any longer correspond to the product-type, the manufacturer should refrain from using this European Technical Assessment as the basis for their declaration of performance.
- 11 All rights of exploitation in any form and by any means of this European Technical Assessment is reserved for UBAtc and the ETA-holder, subject to the provisions of the applicable UBAtc regulations.
- 12 Reproduction of this European Technical Assessment including transmission by electronic means shall be in full. However, partial reproduction can be made with the written consent of UBAtc. In this case partial reproduction has to be designated as such. Texts and drawings of advertising brochures shall not contradict or misuse the European Technical Assessment.
- 13 Subject to the application introduced, this European Technical Assessment is issued in English and may be issued by the UBAtc in its official languages. The translations correspond fully to the English reference version circulated in EOTA.
- 14 This European Technical Assessment was first issued by UBAtc on: 2015-12-08.

¹ OJEU, L 88 of 2011/04/04

² OJEU, L 289 of 2013/10/31

Technical Provisions

1 Technical description of the product

1.1 General

GEOFLAM® F Light is a fire protective plaster board, composed of plaster, vermiculite and/or perlite, mineral fibres and damp-proof if necessary. The product is whitish in colour. The upper surface is smooth and the reverse face is rough.

The GEOFLAM® F Light boards may have rebates.

The Fire Protective Boards are manufactured by GEOSTAFF at production plant 01 (known by UBAtc).

1.2 Dimensions and density

Dimensions and density of the boards are given in Table 1.

Table 1. Dimensions and density GEOFLAM® F Light

Density (dry-80°C): 1050 kg/m ³ ± 15%		
Density (23°C, 50%RH): 1100 kg/m ³ ± 15%		
Thickness (mm)	Length x width (mm)	Tolerances on length width (mm)
35 ± 2	From 1000 x 200 up to 1000 x 1100 (*)	+5/-5
(*) width increases in steps of 50 mm		

On special request other length and width dimensions may be available; respecting the tolerances as specified in Table 1.

1.3 Ancillary products

Ancillary products referred to in this ETA, as a part of installation provisions or in the framework of determining performances (e.g. fire resistance), are not covered by this ETA and may not be CE-marked on the basis of it.

2 Specification of the intended use(s) in accordance with the applicable EAD

2.1 Intended uses

This ETA covers fire protective boards intended for internal use (ETAG 018-4 types Z₂)

GEOFLAM® F Light is intended to protect elements or to be used in assemblies as specified in Table 2.

Table 2 shows the possible intended uses of the boards. Not all of these have been assessed in the framework of this ETA with regard to fire resistance performance. Annex 2 shows a list of the uses for which fire resistance assessment was carried out. This ETA covers assemblies installed in accordance with the provisions given in Annex 2.

With regard to fire resistance performance, the other intended uses may be supported by other means at national level (as specified in the note in paragraph 2.2.1.2 of this ETA).

Table 2. Intended use

Protection of	ETAG 018-1 reference
Horizontal membrane protection incl. suspended ceilings acc. to EN 13964	Type 1
Vertical membrane protection	Type 2
Load-bearing concrete elements	Type 3
Load-bearing steel elements	Type 4
Load-bearing flat concrete profiled sheet composite elements	Type 5
Load-bearing concrete filled hollow steel columns	Type 6
Load-bearing timber elements	Type 7
Fire separating assemblies with no load-bearing requirements	Type 8
Technical services assemblies in buildings	Type 9
Fire protective uses not covered by types 1-9	Type 10

The provisions made in this European Technical Assessment are based on an assumed intended working life of 10 years, provided that the assembled product is subject to appropriate use and maintenance, in accordance with this ETA.

Indications given regarding the working life cannot be interpreted as a guarantee given by the producer or the UBAtc, but are to be regarded only as a means for choosing the appropriate product(s) in relation to the expected economically reasonable working life of the construction works.

2.2 Assumptions under which the fitness of the product(s) for the intended use was favourably assessed

2.2.1 Manufacturing directives

The European technical assessment is issued for the product on the basis of agreed data/information, deposited with the approved body, which identifies the product that has been assessed and judged. Changes to the product or production process, which could result in this deposited data/information being incorrect, should be notified to the approved body before the changes are introduced. The approved body will decide whether or not such changes affect the ETA and consequently the validity of the CE marking on the basis of the ETA and if so whether further assessment or alterations to the ETA, shall be necessary.

The raw materials are dosed and mixed in water before casting in suitable moulds. After a partial drying, the products are removed from the moulds and dried in the oven. Each board is marked in accordance with paragraph 6 of this ETA. Boards are examined for visual defects and non-compliant boards are rejected.

2.2.2 Installation

2.2.2.1 Supporting structure

The distance between supports shall be in accordance with the information provided in the assemblies described in annex 2 of this ETA.

2.2.2.2 Cutting and machining

The GEOFLAM® F Light boards are manufactured in standard dimensions (cf. Table 1 of this ETA). If needed, the fire protective boards can be cut using a handsaw or electric equipment. The latter saw shall operate at a low speed

A safety data sheet is available from the manufacturer upon request.

2.2.2.3 Joints

The fire protective boards shall be butt jointed.

The boards can have square or rabbeted edges. The type of edge shall be in accordance with the assemblies described in annex 2.

The use and type of joint filler shall be in accordance with the assemblies described in annex 2.

2.2.2.4 Assembly

The boards shall be applied as specified in the assemblies in annex 2.

2.3 Recommendations

2.3.1 Recommendations on packaging, transport and storage

During transport and storage, the boards shall be stacked on a flat underground and protected against rain. Storage shall take place on pallets, in a sheltered and well-ventilated space.

2.3.2 Recommendations on use, maintenance and repair

Future modifications to the building should not adversely affect the fire protective properties of the system in which the boards are used. Care should be taken to prevent any reduction of fire performance as a result of increased applied load to protected elements of the works (e.g. beams, columns, ceilings, floors, or walls).

The assessment of the fitness for use is based on the assumption that damaged boards, for example due to accidental impact, are replaced. It is further assumed that replacement of components during maintenance/repair will be undertaken using materials specified by the ETA.

3 Performance of the product and references to the methods used for its assessment

3.1 Mechanical resistance and stability (BWR1)

This basic requirement for construction works is not relevant for GEOFLAM® F Light boards according to ETAG 018.

3.2 Safety in case of fire (BWR2)

3.2.1 Reaction to fire

The GEOFLAM® F Light boards have a reaction to fire classification A1 according to EN 13501-1:2007+A1:2009.

3.2.2 Resistance to fire

Assemblies incorporating GEOFLAM® F Light boards have a resistance to fire when tested according to EN 1366-1, EN 1366-5 or EN 1366-8 and classified according to EN 13501-2, EN 13501-3 or EN 13501-4, (ETAG 018 Part 1, ER2) as presented in Annex 2.

The tested assemblies horizontal and vertical ducts (intended use type 9), have a fire resistance classification as shown in the tables below.

Table 4.a. Horizontal and vertical services	
Horizontal and vertical ducts Internal duct dimensions from 50 mm by 50 mm up to 1250 mm wide by 1000 mm high The services ducts can be loaded up to 50 kg/m Installation details see Annex 2 of the ETA Resistance to fire classifications in accordance to EN 13501-2:2007+A1:2009	
Board thickness (mm)	Classification
35	EI 120 ve ho i ↔ o

Table 4.b. Ventilation Ducts	
Horizontal and vertical ducts Internal duct dimensions up to 1250 mm wide by 1000 mm high Installation details see Annex 2 of the ETA Resistance to fire classifications in accordance to EN 13501-3:2007+A1:2009	
Board thickness (mm)	Classification
35	EI 120 ve ho i ↔ o S

Table 4.c. : Smoke extraction ducts	
Horizontal and vertical ducts Internal duct dimensions up to 1250 mm wide by 1000 mm high Installation details see Annex 2 of the ETA Resistance to fire classifications in accordance to EN 13501-4:2007+A1:2009	
Board thickness (mm)	Classification
35	EI 120 S ve ho -1500 / +500 Pa Multi

NOTE: In accordance with ETAG 018-4 (foreword), until 10 years after the initial issuing of this ETA, or until the withdrawal of relevant national test and classification standards, CE marking will cover a limited number of assemblies subjected to fire resistance assessment. As time progresses, the performance declaration for fire resistance covered by CE marking should gradually be enlarged by the ETA-holder and incorporated in this ETA by amendment or revision. In the meantime, and taking into account the transitional arrangements for test and classification standards and the corresponding national legislation (see EC Guidance paper J), the ETA-holder shall be permitted to maintain and be able to use - on a national basis - his portfolio of test data for this characteristic, based on relevant national standards, next to the performance declaration covered by the CE marking based on this ETA

3.3 Hygiene, health and the environment (BWR3)

3.3.1 Air and/or water permeability

No performance assessed.

3.3.2 Release of dangerous substances

3.3.2.1 General

The GEOFLAM® F Light boards comply with all relevant European and national provisions applicable for the uses for which it is brought to the market.

In addition to this ETA clause relating to dangerous substances, there may be other requirements applicable to the products falling within its scope (e.g. transposed European legislation and national laws, regulations and administrative provisions). In order to meet the provisions of the EU Construction Products Directive, these requirements need also to be complied with, when and where they apply.

3.3.2.2 Release of formaldehyde

The GEOFLAM® F Light boards have no formaldehyde containing components.

3.4 Safety in use (BWR4)

3.4.1 Mechanical resistance and Stability

3.4.1.1 Flexural strength

In accordance with EN 12467, the boards have a modulus of rupture (MOR) of $\geq 1,8$ MPa.

The boards have sufficient strength to support their own mass. The boards are not intended to support additional loads.

3.4.1.2 Dimensional stability

The dimensional stability on width and length, and on thickness of the GEOFLAM® F Light boards tested in accordance with EN 318 is given in the table below.

Table 3. Dimensional stability of GEOFLAM® F Light boards	
Relative change in length or width	
Range	35 mm
65% to 30%	0,0(-0,3/0,1)
65% to 85%	-0,1(-0,2/0,1)
Relative change in thickness	
Range	35 mm
65% to 30%	0,1(-0,2/0,3)
65% to 85%	0,0 (-0,3/0,2)

3.5 Protection against noise (BWR5)

3.5.1 Sound absorption

No performance assessed

3.5.2 Airborne sound insulation

No performance assessed

3.5.3 Impact sound insulation

No performance assessed

3.6 Energy and heat retention (BWR6)

3.6.1 Thermal insulation

No performance assessed

3.6.2 Water vapour transmission coefficient

No performance assessed

3.7 Aspects of durability, serviceability and identification

3.7.1 Durability and serviceability

Product performances confirm a working life of minimum 10 years of the GEOFLAM® F Light boards for the intended use Z₂ (internal use).

3.7.2 Identification

3.7.2.1 Length, Width

The length of the GEOFLAM® F Light boards is 1000 mm as presented in table 1.

The width of the GEOFLAM® F Light boards is between 200 mm and 1100 mm, depending on the thickness of the board, as presented in table 1.

Other lengths and widths, not exceeding the above mentioned maximum dimensions, may be available on special request.

3.7.2.2 Thickness

The thickness of the GEOFLAM® F Light boards is 35 mm as presented in table 1.

3.7.2.3 Dimensional tolerances

The tolerances of the GEOFLAM® F Light boards are ± 5 mm on length and on width. The tolerance on the thickness is ± 2 mm, as presented in table 1.

3.7.2.4 Shape

The straightness of the edges and the squareness of the GEOFLAM® F Light boards respect the level II criteria of clause 5.3.5 in EN 12467.

3.7.2.5 Apparent density

The apparent density of the boards is $1100\text{kg/m}^3 \pm 15\%$.

4 Assessment and verification of constancy of performance (AVCP) system applied, with reference to its legal base

In accordance with Regulation (EU) N° 305/2011, Directive 89/106/EEC is repealed, but references to the repealed Directive shall be construed as references to the Regulation.

The system(s) of assessment and verification of constancy of performance, specified in the Decision of the Commission 1999/454/EC of 1999/07/14³, are specified in the following Table.

Table 4. System of assessment and verification of constancy of performance applicable for GEOFLAM® F Light boards			
Product(s)	Intended use(s)	Level(s) or class(es)	Assessment and verification of constancy of performance system(s) ^(a)
Fire protective products	For fire compartmentation and/or fire protection or fire performance	Any	1

^(a) See Annex V to Regulation (EU) N° 305/2011

In addition, according to the Commission Decision 1999/454/EC¹, as amended, the system of assessment and verification of constancy of performance given in Table 6 apply to fire protective products with regard to reaction to fire.

Table 5. The system of assessment and verification of constancy of performance applicable fire protective products with respect to reaction to fire			
Product(s)	Intended use(s)	Level(s) or class(es) (reaction to fire)	Assessment and verification of constancy of performance system(s) ^(a)
Fire protective products	For uses subject to regulations on reaction to fire	(A1, A2, B, C)*	1
		(A1, A2, B, C)**, D, E	3
		(A1 to E)***, F	4

^(a) System 1, 3 and 4 : See Regulation (EU) N° 305/2011, Annex V
 * Products/materials for which a clearly identifiable stage in the production process results in an improvement of the reaction to fire classification (e.g. an addition of fire retardants or a limiting of organic material)
 ** Products/materials not covered by footnote (*)
 *** Products/materials that do not require to be tested for reaction to fire (e.g. products/materials of class A1 according to Commission Decision 96/603/EC⁴, as amended)

For initial type testing of the product the task for the notified body is limited to the following characteristics:

- Reaction to fire
- Resistance to fire
- Mechanical resistance and stability
- Release of dangerous substances

For initial inspection of the factory and of FPC, and for continuous surveillance, judgment and assessment of the FPC, parameters related to the following characteristics are of interest to the notified body:

- Reaction to fire
- Mechanical resistance and stability

The system of Assessment and verification of constancy of performance is specified in the EC Decision 99/454/EC, as amended by EC Decision 2001/596/EC⁴, is system 1, 3 or 4, depending on the classes declared.

For Fire protective Products under systems 1 and 3, regarding the initial type testing of the product, the task for the notified laboratory is limited to the assessment of the Euroclass characteristics for reaction to fire, as indicated in the Commission Decision 94/611/EC⁵.

For Fire Protective Products under system 1, for initial inspection of the factory and of FPC, and for continuous surveillance, assessment and approval of the FPC, parameters related to the Euroclass characteristics for reaction to fire, as indicated in the Commission Decision 94/611/EC are of interest of the notified body.

³ OJEU L178/52 of 1999/07/14

⁴ OJ L209 of 2001/08/02

⁵ OJ L241/25 of 1996/09/16

5 Technical details necessary for the implementation of the AVCP system, as foreseen in ETAG 018-1 and ETAG 018-4

5.1 Tasks for the ETA-holder

5.1.1 Factory production control (FPC)

The ETA-holder shall exercise permanent internal control of the production. All the elements, requirements and provisions adopted by the ETA-holder shall be documented in a systematic manner in the form of written policies and procedures. This factory production control system shall ensure that production is in conformity with this ETA.

The personnel involved in the production process shall be identified, sufficiently qualified and trained to operate and maintain the production equipment. Machinery equipment shall be regularly maintained and this shall be documented. All processes and procedures of production shall be recorded at regular intervals.

The ETA-holder shall maintain a traceable documentation of the production process from purchasing or delivery of raw or basic raw materials up to the storage and delivery of finished products.

The factory production control system for the product includes relevant design specifications, including adequate drawings and written instructions for:

- type and quality of all materials
- overall dimensions
- packaging and transport protection

The production control system shall specify how the control measures are carried out, and at which frequencies.

ETA-holders which have an FPC system that complies with EN ISO 9001 and that addresses the requirements of this ETA are recognised as satisfying the FPC requirements.

Products that do not comply with requirements as specified in the ETA shall be separated from the conforming products and marked as such. The ETA-holder shall register non-compliant production and action(-s) taken to prevent further non-conformities. External complaints shall also be documented, as well as actions taken.

When materials/products are delivered for incorporation into the production process, verification of conformity with specifications in the quality manual shall take place and recorded

If supplied materials/components are not manufactured and tested by the supplier in accordance with agreed methods, or where the ETA-holder purchases materials/components on the open market, then where appropriate, they shall be subject to suitable documented checks/tests by the ETA-holder before acceptance.

The characteristics of incoming material and components, for which the supplier demonstrates documented compliance with a product specification, for an intended use that is appropriate for its use as a raw material or component of the product, shall be considered satisfactory and need, except in justified doubt, no further checking, unless the control plan specifies differently.

5.1.2 Testing of samples taken at the factory

5.1.2.1 General

At least the following minimum information shall be recorded:

- date and time of manufacture
- type of product produced (boards)
- material specification (dimensions and thickness)
- all results of the verifications performed within the agreed upon control plan

5.1.2.2 Maintenance, checking and calibration of equipment

All testing equipment shall be maintained, calibrated and/or checked against equipment or test specimens traceable to relevant international or nationally recognised reference test specimens (standards). In case no such reference test specimens exist, the basis used for internal checks and calibration shall be documented.

The ETA-holder shall ensure that handling, preservation and storage of test equipment is such that its accuracy and fitness for purpose is maintained

When production is intermittent, the ETA-holder shall ensure that any test equipment which may be affected by the interruption is suitably checked and/or calibrated before use. The calibration of all test equipment shall be repeated if any repair or failure occurs which could upset the calibration of the test equipment.

5.1.2.3 Testing as part of Factory Production Control

Table 6 specifies minimum requirements for testing as part of the FPC.

If constituent materials or components are supplied by other manufacturers to the ETA-holder, the supplier shall perform FPC on those constituent materials or components. If that is the case, those suppliers should submit the relevant records to the ETA-holder.

Property	Minimum frequency
Determination of organic content (reaction to fire)	1 per week ⁶
Determination of dimensional stability at high temperatures (fire resistance)	1 per week
Indirect test method (small oven test) ⁷	1 per year
Dimensional stability	1 per year

⁶ A week represents 5 production days.

⁷ Production shall be subjected to a small oven test (test performed on one thickness).

Table 6. FPC test plan for GEOFLAM® F Light boards	
Property	Minimum frequency
Identification	
length, width	1 per day ⁸ , per dimension
thickness	1 per day, per thickness
apparent density	1 sample per n-boards
Flexural strength	1 sample per n-boards

5.2 Initial Type Testing

The assessment tests will have been conducted by the UBAtc or under its responsibility (which may include a proportion conducted by an independent laboratory or by the ETA-applicant, witnessed by the UBAtc). The UBAtc will have assessed the results of these tests in accordance with chapter 3 of this ETA, as part of the ETA issuing procedure.

6 Other marking and/or information

Each board shall at least be marked with product name and a traceability code. Each package is marked with the product name, traceability code, thickness of the boards, and dimensions of the boards.

UBAtc asbl is a non-profit organization according to Belgian law. It is a Technical Assessment Body notified by the Belgian notifying authority, the Federal Public Services Economy, SMEs, Self-Employed and Energy, on 17 July 2013 in the framework of Regulation (EU) No 305/2011 of the European Parliament and of the Council of 9 March 2011 laying down harmonised conditions for the marketing of construction products and repealing Council Directive 89/106/EEC and is member of the European Organisation for Technical Assessment, EOTA (www.eota.eu).

This European Technical Assessment has been issued by UBAtc asbl on the basis of the technical work carried out by the Assessment Operator, BCCA.

On behalf of UBAtc asbl,



Peter Wouters,
director

On behalf of the Assessment Operator, BCCA,
responsible for the technical content of the
ETA,



Benny De Blaere,
director general

The most recent version of this European Technical Assessment may be consulted on the UBAtc website (www.ubatc.be).

⁸ A day represents a 24h time period in which production is considered to be as usual for the production facility concerned.

Annexes

Annex I : References

Reference number ETAG 018-1 (edition 2004)
Document title Fire protective products - Part 1: General.

Reference number ETAG 018-4 (edition 2004)
Document title Fire protective products - Part 4: Fire protective board, slab and mat products and kits.

Reference number EN 13964:2004
Document title Suspended ceilings - Requirements and test methods.

Reference number EN 12467:2004
Document title Fibre-cement flat sheets - Product specification and test methods

Reference number EN 13501-1:2002
Document title Fire classification of construction products and building elements - Part 1: Classification using test data from reaction to fire tests

Reference number EN 13501-2:2003
Document title Fire classification of construction products and building elements - Part 2: Classification using data from fire resistance tests, excluding ventilation services

Reference number EN 13501-3:2006
Document title Fire classification of construction products and building elements - Part 3: Classification using data from fire resistance tests on products and elements used in building service installations: fire resisting ducts and fire dampers

Reference number EN 13501-4:2007
Document title Fire classification of construction products and building elements - Part 4: Classification using data from fire resistance tests on components of smoke control systems

Reference number EN 1364-1:1999
Document title Fire resistance tests for non-loadbearing elements- Part 1: Walls

Reference number EN 1366-1:1999
Document title Fire resistance tests for service installations - Part 1: Ducts

Reference number EN 1366-5:2010
Document title Fire resistance tests for service installations - Part 5: Service ducts and shafts

Reference number EN 1366-8:2004
Document title Fire resistance tests for service installations - Part 8: Smoke extraction ducts

Reference number EN 318:2002
Document title Wood based panels - Determination of dimensional changes associated with changes in relative humidity

Reference number EN ISO 354:2003
Document title Acoustics - Measurement of sound absorption in a reverberation room (ISO 354:2003)

Reference number EN ISO 11654:1997
Document title Acoustics - Sound absorbers for use in buildings - Rating of sound absorption (ISO 11654:1997)

Reference number EN ISO 140-3:1995
Document title Acoustics - Measurement of sound insulation in buildings and of building elements - Part 3: Laboratory measurements of airborne sound insulation of building elements (ISO 140-3:1995)

Reference number EN ISO 717-1:1996
Document title Acoustics - Rating of sound insulation in buildings and of building elements - Part 1: Airborne sound insulation

NOTE: The editions of reference documents given above are those which have been adopted by the UBAtc for its specific use when establishing this ETA. When new editions become available, these supersede the editions mentioned only when confirmed by the UBAtc.

Annex II : Fire resistance performances and assembly methods for uses of boards covered by this ETA

Annex 2.0: Overview of fire resistance performances for GEOFLAM® F Light assemblies

The fire protective assemblies in Table A.2.0.1 have been assessed within the framework of this ETA. Assemblies installed according to the provisions given in this annex are covered by this ETA.

Table A.2.0.1

Assembly assessed within the framework of this ETA	Classification according to EN 13501-2	Test standard	Intended use *	Installation details	Date of addition to this ETA
Horizontal and vertical protection of service ducts and shafts composed of GEOFLAM®F Light fire protective boards	EI 120 ve ho i ↔ o	EN 1366-5	Type 9	Annex 2.1	2015-12-08
Assembly assessed within the framework of this ETA	Classification according to EN 13501-3	Test standard	Intended use *	Installation details	Date of addition to this ETA
Horizontal and vertical ventilation ducts composed of GEOFLAM® F Light	EI 120 ve ho i ↔ o S	EN 1366-1	Type 9	Annex 2.2	2015-12-08
Assembly assessed within the framework of this ETA	Classification according to EN 13501-4	Test standard	Intended use *	Installation details	Date of addition to this ETA
Horizontal and vertical smoke extraction ducts composed of GEOFLAM® F Light	EI 120 S ve ho -1500 / +500 Pa Multi	EN 1366-8	Type 9	Annex 2.3	2015-12-08

* Intended use type according to ETAG 018

Annex 2.1: Specification of service ducts and shafts (intended use type 9), composed of GEOFLAM® F Light fire protective boards,

A.2.1.1 Date of addition to this ETA

This annex was added to ETA 15/0653 on 2015-12-08. This assembly was not covered by this ETA prior to the addition of this annex.

A.2.1.2 Classification

The assembly described in this annex has been tested according to EN 1366-5 and classified (see table A.2.0.1) in accordance with EN 13501-2.

A.2.1.3 Installation requirements

Installation requirements in paragraph 2.2 of this ETA shall be taken into account.

A.2.1.4. Horizontal ducts

A.2.1.4.1 Supporting structure

The continuous self-supporting horizontal duct is composed of GEOFLAM® F Light fire protective boards (see paragraph A.2.1.4.3 for details of the duct composition). The duct penetrates walls with a minimum thickness of 150 mm (or a partition with an equivalent resistance to fire performance characteristics – see paragraph A.2.1.4.4.2 for details of penetration). The duct is supported by steel suspension system at intervals of 1000 mm, as illustrated by figures 2.1.4.1.

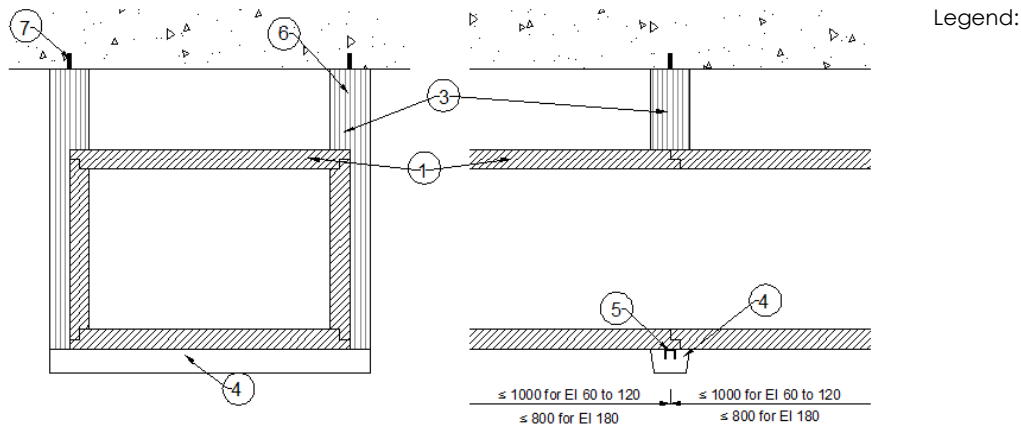

- ① : GEOFLAM® F Light boards
- ③ : GEOFLAM® A fire protective half-shells
- ④ : GEOFLAM® A fire protective U-profile
- ⑤ : Galvanized steel U-profile
- ⑥ : Galvanized steel rods
- ⑦ : Anchor

Fig. 1: Figure 2.1.4.1: Horizontal duct composed of GEOFLAM® F Light fire protective boards

The system is suspension composed with:

- Galvanized steel rods with a diameter M8
- Galvanized steel U-profiles – Dimensions : 25 x 25 x 25 x 2 mm

The supporting structure is protected whether the duct is exposed to fire from outside or from inside.

Specifications for the components are given in Table A.2.1.4.1.

ETA GEOFLAM®F Light

Table A.2.1.4.1

Element	Identification	Characteristics	Mounting and fixing
Rods	Galvanized steel rods	M8	1000 mm centre distance
Steel U-profiles	Galvanized steel U-profiles	Dimensions : 25 x 25 x 25 x 2 mm Length : depending of the duct section	1000 mm centre distance

A.2.1.4.2 Insulation

The galvanized steel rods are protected with fire protective shells (Ø 90 mm). The shells are composed of two half-pieces applied on the rods and fixed with GEOCOL® glue.

The galvanized steel U-profiles are protected with fire protective U-profiles (100 x 60 mm).

Specifications for the components are given in Table A.2.1.4.2

Table A.2.1.4.2

Element	Identification	Characteristics	Mounting and fixing
Half-shells	GEOFLAM® A	Length: 1000 mm Diameter: Ø 90	Placed on steel rods and maintained with GEOCOL® glue (or equivalent)
U-profile protections	GEOFLAM® A	Length: 1000 mm Width: 100 mm Thickness: 60 mm	Placed on steel U-profiles and maintained with GEOCOL® glue (or equivalent)

A.2.1.4.3. Fire protective boards

The GEOFLAM® F Light boards are placed to form a continuous horizontal duct (see figures 2.1.4.1).

The boards are fixed together with GEOCOL® glue or equivalent at all edges and in the rabbets.

Dimensions:

Dimensions (lx h)	Mounting
Minimum 50 x 50 mm Maximum 1250 x 1000 mm	

Fig. 1: Figure 2.1.4.3 : Horizontal duct composed of GEOFLAM® F Light fire protective boards

When the inner width of the duct exceeds 1000 mm, two boards must be installed on top and below the duct. In this case, another steel rod and steel U-profile have to be placed. Both steel rod and steel U-profile shall be protected with GEOFLAM® A elements (see Table A.2.1.4.2) when the duct may be exposed to fire from inside.

Specifications for the components are given in Table A.2.1.4.3.

Table A.2.1.4.3

Element	Identification	Characteristics	Mounting and fixing
Board	GEOFLAM® F Light	Thickness: 35mm Length: 1000 mm Width: See table 2	Installed to form a rectangular horizontal duct
Glue	GEOCOL® or equivalent	Gypsum based adhesive, in powder form	Used for fixing of the board

A.2.1.4.4: Joints

A.2.1.4.4.1: Board joints

All internal and external joints are filled with GEOCOL® glue or equivalent and finished with a mixture of vegetable fibres and bonding plaster.

Specifications for the components are given in Table A.2.1.4.4.1

Table A.2.1.4.4.1

Element	Identification	Characteristics	Mounting and fixing
Glue	GEOCOL® or equivalent	Gypsum based adhesive, in powder form	Applied with a spatula. The joints are completely filled up.
“Polochon”	Sisal + GEOPLATRE® N (or equivalent)	Mixture of Sisal fibres and bonding plaster	The mixture is applied on all internal and external joints. The joints are completely covered.

A.2.1.4.4.2: Penetration seal

The gap between the penetration wall and the duct is filled up with mineral wool (A1 classified according to EN 13501-1, density $\geq 120 \text{ kg/m}^3$) or with a mixture of vegetable fibers and bonding plaster (see figure 2.1.4.4.2).

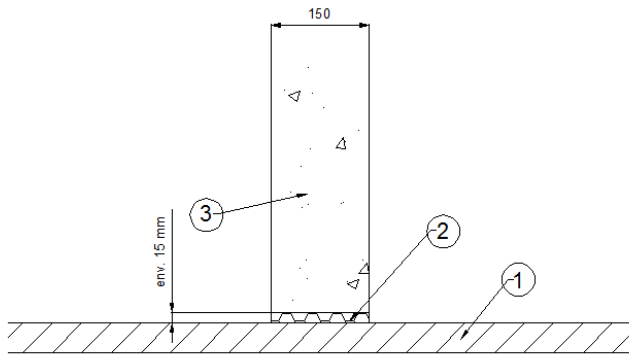

Legend:

- ① GEOFLAM® F Light boards
- ② gap (about 15 mm) to be filled with Rockwool, density $\geq 120 \text{ kg/m}^3$ or mixture of vegetable fibers and bonding plaster
- ③ Penetration wall

Figure 2.1.4.4.2

Specifications for the components are given in Table A.2.1.4.4.2

Table A.2.1.4.4.2

Element	Identification	Characteristics	Mounting and fixing
Plugging/sealing material	Mineral wool	Density $\geq 120 \text{ kg/m}^3$	Apply between the penetration wall and the duct
“Polochon”	Sisal + GEOPLATRE® N (or equivalent)	Mixture of Sisal fibers and bonding plaster	The mixture is applied in the gap between the penetration wall and the duct

A.2.1.4.5 Details

All installation details shall be executed as presented in figures 2.1.4.1. and 2.1.4.3.

A.2.1.4.6 Field of direct application

The results of the fire test are directly applicable to similar constructions where one or more of the changes listed below are made and the construction continues to comply with the appropriate design code for its stiffness and stability.

- The internal dimensions of the ducts are between 50 mm and 1250 mm in width by between 50 mm and 1000 mm in height.
- The duct is installed horizontally
- The duct may penetrate walls made of bricks or concrete, with a thickness superior to 150 mm and a density superior to 650 kg/m^3
- The ducts may be loaded with additional charges inferior to 50 kg/m
- The tensions in the supporting structure are limited as follows

ETA GEOFLAM®F Light

	Maximum allowed stresses (N/mm²)
Tensile stresses in all vertically oriented elements	6
shear stress on the screws of property class 4.6 according to EN ISO 898-1	10
Note : the stresses are calculated for the supported load only (and neglecting the assembly loads)	

A.2.1.5. Vertical ducts

A.2.1.5.1 Supporting structure

The continuous self-supporting vertical duct is composed of GEOFLAM® F Light fire protective boards (see paragraph A.2.1.5.3 for details of the duct composition). The duct penetrates concrete floors with a minimum thickness of 150 mm (see paragraph A.2.1.5.4.2 for details of penetration). The duct starts at ground level and penetrates a steel reinforced concrete floor (or a floor slab with an equivalent resistance to fire performance characteristics) with a minimum thickness of 150 mm. At the opening in the floor, the duct is supported by board fillets on two parallels sides (see figure 2.1.5.1).

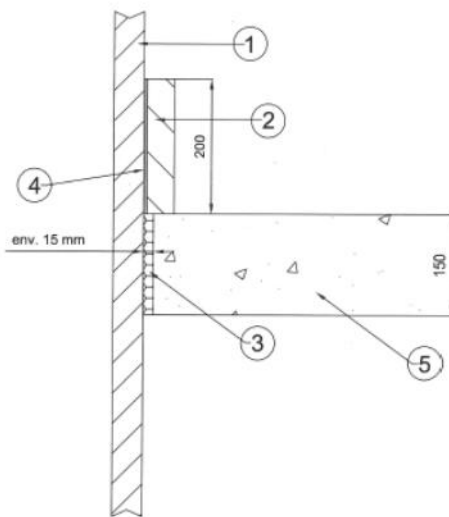

Legend :

- ① : GEOFLAM® F Light boards
- ② : GEOFLAM® A board fillets
- ③ : gap (about 15 mm) to be filled with Rockwool, density $\geq 120 \text{ kg/m}^3$ or mixture of vegetable fibers and bonding plaster
- ④ : GEOCOL® glue
- ⑤ : Steel reinforced concrete floor

Fig. 2: Figure 2.1.5.1: Vertical duct composed of GEOFLAM® F Light fire protective boards

Specifications for the components are given in Table A.2.1.5.1.

Table A.2.1.5.1

Element	Identification	Characteristics	Mounting and fixing
Board fillet	GEOFLAM® A	Thickness : Same as the duct Height : 200 mm	Glued on the duct and only supported on the concrete floor
Glue	GEOCOL® or equivalent	Gypsum based adhesive, in powder form	Used for fixing of the board fillets on the duct

NB: maximum height without supporting structure:

- 7 m (with board fillets on two parallels sides)
- 10 m (with board fillets on three sides of the duct)

A.2.1.5.2 Insulation

None

A.2.1.5.3. Fire protective boards

The GEOFLAM® F Light boards are placed to form a continuous vertical duct (see figures 2.1.5.3).

The boards are fixed together with GEOCOL® glue or equivalent at all edges and in the rabbets.

Maximum dimensions of duct are 1250 mm by 1000 mm (internal dimensions)

Specifications for the components are given in Table A.2.1.5.3

Table A.2.1.5.3

Element	Identification	Characteristics	Mounting and fixing
Board	GEOFLAM® F Light	Thickness: 35mm Length: 1000 mm Width: See table 2	Installed to form a rectangular vertical form
Glue	GEOCOL® or equivalent	Gypsum based adhesive, in powder form	Used for fixing of the board

A.2.1.5.4: Joints

A.2.1.5.4.1: Board joints

All internal and external joints are filled with GEOCOL® glue or equivalent and finished with a mixture of vegetable fibres and bonding plaster.

Specifications for the components are given in Table A.2.1.5.4.1

Table A.2.1.5.4.1

Element	Identification	Characteristics	Mounting and fixing
Glue	GEOCOL® or equivalent	Gypsum based adhesive, in powder form	Applied with a spatula. The joints are completely filled up.
"Polochon"	Sisal + GEOPLATRE® N (or equivalent)	Mixture of Sisal fibres and bonding plaster	The mixture is applied on all internal and external joints. The joints are completely covered.

A.2.1.5.4.2: Penetration seal

The gap between the slab and the duct is filled up with mineral wool (A1 classified according to EN 13501-1, density ≥ 120 kg/m³) or with a mixture of vegetable fibers and bonding plaster (see figure 2.1.5.5).

Specifications for the components are given in Table A.2.1.5.4.2

Table A.2.1.5.4.2

Element	Identification	Characteristics	Mounting and fixing
Plugging/sealing material	Mineral wool	Density ≥ 120 kg/m³	Apply between the penetration slab and the duct
"Polochon"	Sisal + GEOPLATRE® N (or equivalent)	Mixture of Sisal fibers and bonding plaster	The mixture is applied in the gap between the penetration slab and the duct

A.2.1.5.5 Details

All installation details shall be executed as presented in figure 2.1.5.5.

ETA GEOFLAM®F Light

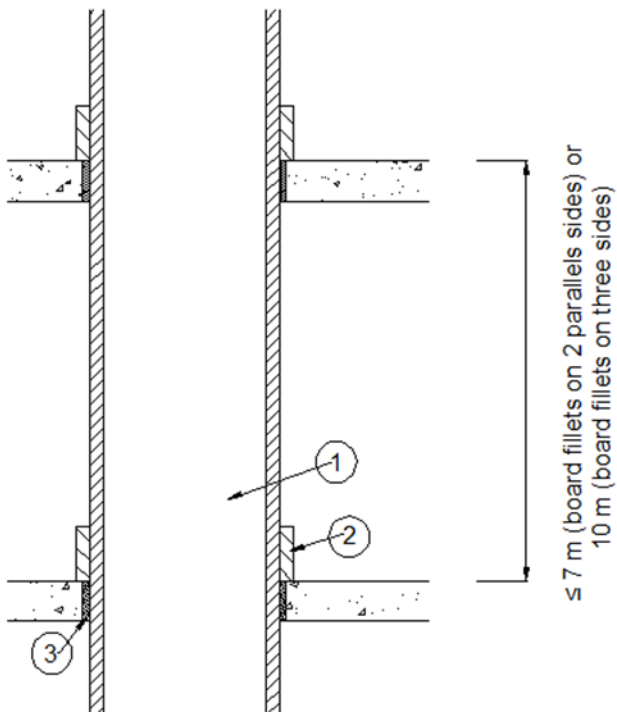

Legend:

- ① GEOFLAM® F Light boards
- ② GEOFLAM® A board fillets
- ③ gap (about 15 mm) to be filled with Rockwool, density $\geq 120 \text{ kg/m}^3$ or mixture of vegetable fibers and bonding plaster

Figure 2.1.5.5

A.2.1.5.6 Field of direct application

The results of the fire test are directly applicable to similar constructions where one or more of the changes listed below are made and the construction continues to comply with the appropriate design code for its stiffness and stability.

- The internal dimensions of the ducts are between 50 mm and 1000 mm in width by between 50 mm and 1250 mm in height.
- The duct is installed vertically
- The duct may penetrate concrete slabs, with a thickness superior to 150 mm and a density superior to 650 kg/m^3

Annex 2.2: Specification of ventilation ducts (intended use type 9), composed of GEOFLAM® F Light fire protective boards,

A.2.2.1 Date of addition to this ETA

This annex was added to ETA 15/0653 on 2015-12-08. This assembly was not covered by this ETA prior to the addition of this annex.

A.2.2.2 Classification

The assembly described in this annex has been tested according to EN 1366-1 and classified (see table A.2.0.1) in accordance with EN 13501-3.

A.2.2.3 Installation requirements

Installation requirements in paragraph 2.2 of this ETA shall be taken into account.

A.2.2.4. Horizontal ducts

A.2.2.4.1 Supporting structure

The continuous self-supporting horizontal duct is composed of GEOFLAM® F Light fire protective boards (see paragraph A.2.2.4.3 for details of the duct composition). The duct penetrates walls with a minimum thickness of 150 mm (or a partition with an equivalent resistance to fire performance characteristics – see paragraph A.2.2.4.2 for details of penetration). The duct is supported by steel suspension system at intervals of 1000 mm as illustrated by figures 2.2.4.1.

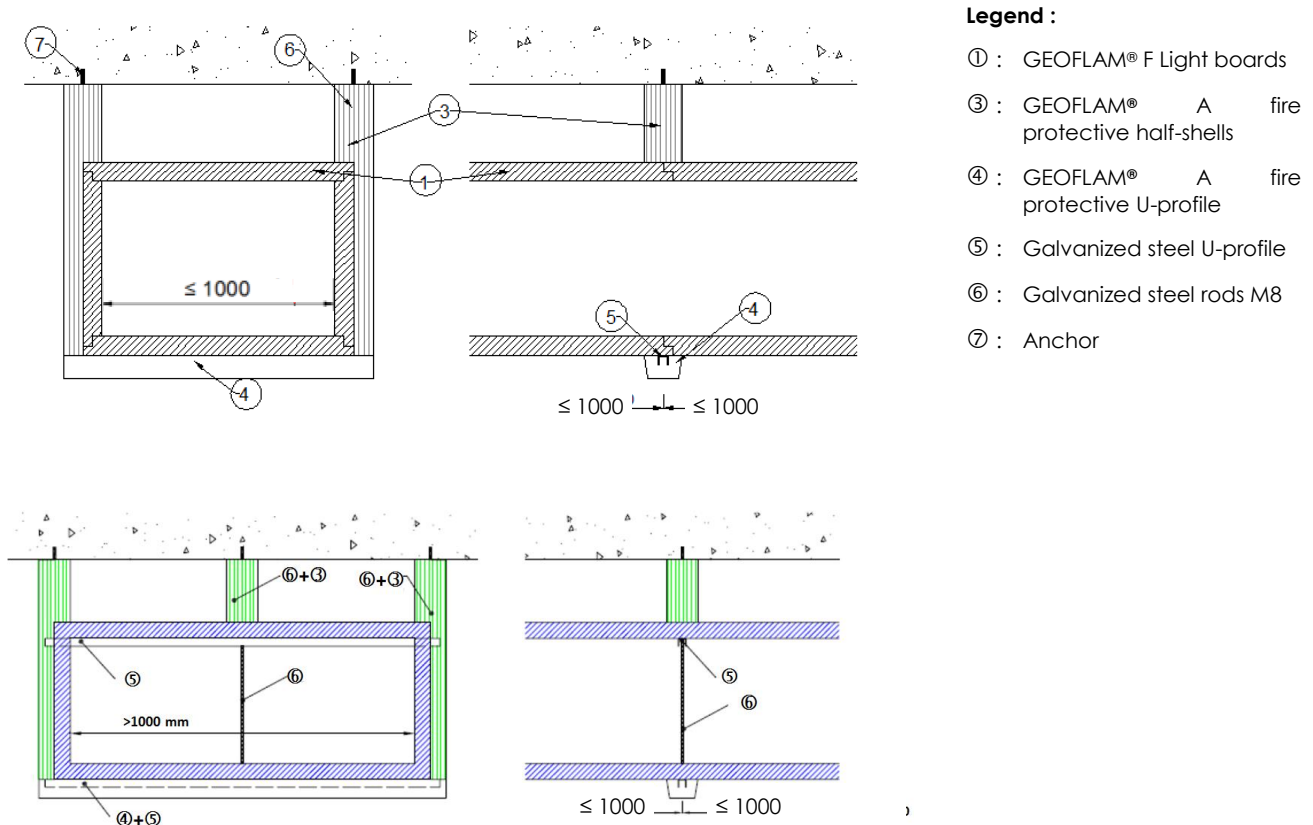

Fig. 3: Figure 2.2.4.1: Horizontal duct composed of GEOFLAM® F Light fire protective boards

The suspension system is composed with:

- Galvanized steel rods with a diameter M8
- Galvanized steel U-profiles – Dimensions : 25 x 25 x 25 x 2 mm

The supporting structure is protected whether the duct is exposed to fire from outside or from inside.

Specifications for the components are given in Table A.2.2.4.1.

ETA GEOFLAM®F Light

Table A.2.2.4.1

Element	Identification	Characteristics	Mounting and fixing
Rods	Galvanized steel rods	M8 : 2 rods at a centre distance of external width + 20 mm for external width inferior to 1000 mm 1 additional rod in the middle for external width superior to 1000 mm	1000 mm centre distance
Steel U-profiles	Galvanized steel U-profiles	<ul style="list-style-type: none"> • Dimensions : 25 x 25 x 25 x 2 mm • Length : External width of the duct + 50 mm • 1 profile (under lower board of the duct) for internal duct width up to 1000 mm • 2 profiles (under lower and upper board of the duct) for internal duct width superior to 1000 mm 	1000 mm centre distance

A.2.2.4.2 Insulation

The galvanized steel rods are protected with fire protective shells (Ø 90 mm). The shells are composed of two half-pieces applied on the rods and fixed with GEOCOL® glue.

The galvanized steel U-profiles are protected with fire protective U-profiles (100 x 60 mm).

Specifications for the components are given in Table A.2.2.4.2

Table A.2.2.4.2

Element	Identification	Characteristics	Mounting and fixing
Half-shells	GEOFLAM® A	Length: 1000 mm Diameter: Ø 90 mm	Placed on steel rods and maintained with GEOCOL® glue (or equivalent)
U-profile protections	GEOFLAM® A	Length: 1000 mm Width: 100 mm Thickness: 60	Placed on steel U-profiles and maintained with GEOCOL® glue (or equivalent)

A.2.2.4.3. Fire protective boards

The GEOFLAM® F Light boards are placed to form a continuous horizontal duct (see figures 2.2.4.1).

The boards are fixed together with GEOCOL® glue or equivalent at all edges and in the rabbets.

Maximum dimensions:

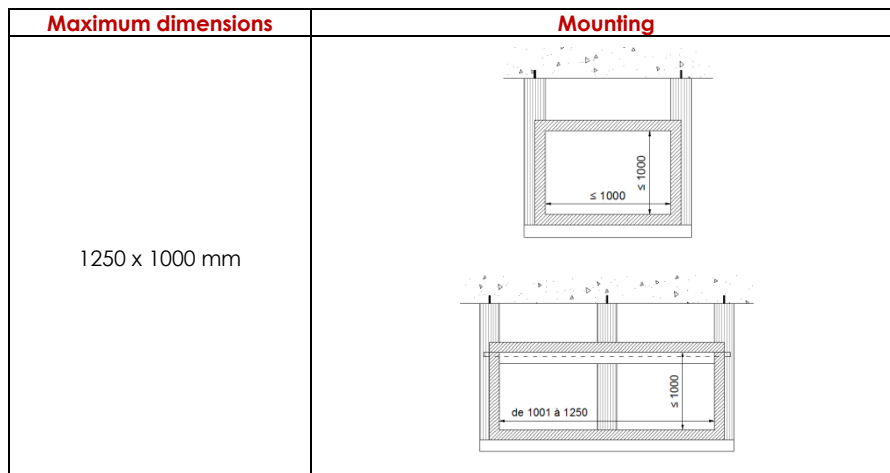

Fig. 4: Figure 2.2.4.3 : Horizontal duct composed of GEOFLAM® F Light fire protective boards

When the inner width of the duct exceeds 1000 mm, two boards must be installed on top and below the duct. In this case, another steel rod and steel U-profile have to be placed (see clause A2.2.4.1).

Specifications for the components are given in Table A.2.2.4.3.

ETA GEOFLAM®F Light

Table A.2.2.4.3

Element	Identification	Characteristics	Mounting and fixing
Board	GEOFLAM® F Light	Thickness: 35 mm Length: 1000 mm Width: See table 2	Installed to form a rectangular horizontal duct
Glue	GEOCOL® or equivalent	Gypsum based adhesive, in powder form	Used for fixing of the board

A.2.2.4.4: Joints

A.2.2.4.4.1: Board joints

All internal and external joints are filled with GEOCOL® glue or equivalent and finished with a mixture of vegetable fibres and bonding plaster. The dimension of this joint finishing is 20 x 20 mm on the corners joints and 50 mm x 10 mm on all other joints.

Specifications for the components are given in Table A.2.2.4.4.1

Table A.2.2.4.4.1

Element	Identification	Characteristics	Mounting and fixing
Glue	GEOCOL® or equivalent	Gypsum based adhesive, in powder form	Applied with a spatula. The joints are completely filled up.
"Polochon"	Sisal + GEOPLATRE® N (or equivalent)	Mixture of Sisal fibres and bonding plaster	The mixture is applied on all internal and external joints. The joints are completely covered.

A.2.2.4.4.2: Penetration seal

The gap between the penetrated wall and the duct is about 15 mm on all sides of the duct. It is filled up with mineral wool (A1 classified according to EN 13501-1, density $\geq 120 \text{ kg/m}^3$) or with a mixture of vegetable fibers and bonding plaster ("Polochon")(see figure 2.2.4.4.2).

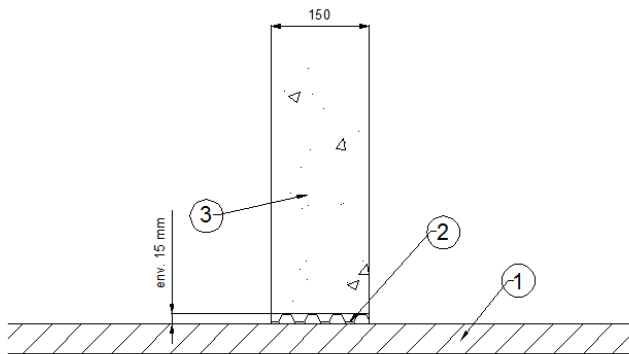

Legend:

- ① GEOFLAM® F Light boards
- ② gap (about 15 mm) to be filled with Rockwool, density $\geq 120 \text{ kg/m}^3$ or mixture of vegetable fibers and bonding plaster
- ③ Penetration wall

Figure 2.1.4.4.2

Specifications for the components are given in Table A.2.2.4.4.2

Table A.2.2.4.4.2

Element	Identification	Characteristics	Mounting and fixing
Plugging/sealing material	Mineral wool	Density $\geq 120 \text{ kg/m}^3$	The mineral wool is applied in the gap between the penetrated wall and the duct over the complete thickness of the wall
"Polochon"	Sisal + GEOPLATRE® N (or equivalent)	Mixture of Sisal fibers and bonding plaster	The "Polochon" applied in the gap between the penetrated wall and the duct over the complete thickness of the wall

A.2.2.4.5 Details

All installation details shall be executed as presented in figures 2.2.4.1. and 2.2.4.3.

A.2.2.4.6 Field of direct application

The results of the fire test are directly applicable to similar constructions where one or more of the changes listed below are made and the construction continues to comply with the appropriate design code for its stiffness and stability.

- Each of the 4 sides of the duct is composed of GEOFLAM® F Light -boards
- The internal dimensions of the ducts are up to 1250 mm in width and up to 1000 mm in height.
- The duct is installed horizontally
- The duct may penetrate walls made of bricks or concrete, with a thickness superior to 150 mm and a density superior to 650 kg/m³
- The ducts may be subject to an overpressure or an under pressure of 500Pa in case of fire

A.2.2.5. Vertical ducts

A.2.2.5.1 Supporting structure

The continuous self-supporting vertical duct is composed of GEOFLAM® F Light fire protective boards (see paragraph A.2.2.5.3 for details of the duct composition). The duct penetrates concrete floors with a minimum thickness of 150 mm (see paragraph A.2.2.5.4.2 for details of penetration). The duct starts at ground level and penetrates a steel reinforced concrete floor (or a floor slab with an equivalent resistance to fire performance characteristics) with a minimum thickness of 150 mm. At the opening in the floor, the duct is supported by board fillets (200 mm high and same thickness as the duct) on two parallels sides (see figure 2.2.5.1). For ducts with sections composed of 4 boards, these fillets are glued to the smaller side of the duct. For ducts with sections composed of more than 4 boards, the fillets are glued to the composed sides of the duct.

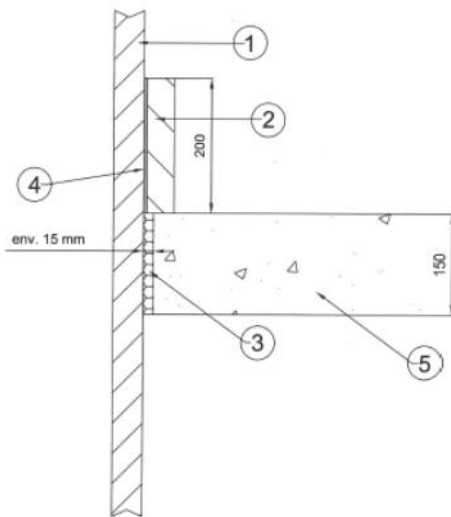

Legend :

- ① : GEOFLAM® F Light boards
- ② : GEOFLAM® A board fillets
- ③ : gap (about 15 mm) to be filled with Rockwool, density $\geq 120 \text{ kg/m}^3$ or mixture of vegetable fibers and bonding plaster
- ④ : GEOCOL® glue
- ⑤ : Steel reinforced concrete floor

Fig. 5: Figure 2.2.5.1: Vertical duct composed of GEOFLAM® F Light fire protective boards

Specifications for the components are given in Table A.2.2.5.1.

Table A.2.2.5.1

Element	Identification	Characteristics	Mounting and fixing
Board fillet	GEOFLAM® A	Thickness : Same as the duct Height : 200 mm	Glued on the duct and only supported on the concrete floor
Glue	GEOCOL® or equivalent	Gypsum based adhesive, in powder form	Used for fixing of the board fillets on the duct

NB: maximum height without supporting structure:

- 7 m (with board fillets on two parallels sides)
- 10 m (with board fillets on three sides of the duct)

A.2.2.5.2 Insulation

None

A.2.2.5.3. Fire protective boards

The GEOFLAM® F Light boards are placed to form a continuous vertical duct (see figures 2.2.5.3).

The boards are fixed together with GEOCOL® glue or equivalent at all edges and in the rabbets.

Maximum dimensions of duct are 1250 mm by 1000 mm (internal dimensions)

Specifications for the components are given in Table A.2.2.5.3

Table A.2.2.5.3

Element	Identification	Characteristics	Mounting and fixing
Board	GEOFLAM® F Light	Thickness: 35 mm Length: 1000 mm Width: See table 2	Installed to form a rectangular vertical form
Glue	GEOCOL® or equivalent	Gypsum based adhesive, in powder form	Used for fixing of the board

A.2.2.5.4: Joints

A.2.2.5.4.1: Board joints

All internal and external joints are filled with GEOCOL® glue or equivalent and finished with a mixture of vegetable fibres and bonding plaster.

Specifications for the components are given in Table A.2.2.5.4.1

Table A.2.2.5.4.1

Element	Identification	Characteristics	Mounting and fixing
Glue	GEOCOL® or equivalent	Gypsum based adhesive, in powder form	Applied with a spatula. The joints are completely filled up.
"Polochon"	Sisal + GEOPLATRE® N (or equivalent)	Mixture of Sisal fibres and bonding plaster	The mixture is applied on all internal and external joints. The joints are completely covered.

A.2.2.5.4.2: Penetration seal

The gap between the slab and the duct is filled up with mineral wool (A1 classified according to EN 13501-1, density $\geq 120 \text{ kg/m}^3$) or with a mixture of vegetable fibers and bonding plaster (see figure 2.2.5.5).

Specifications for the components are given in Table A.2.2.5.4.2

Table A.2.2.5.4.2

Element	Identification	Characteristics	Mounting and fixing
Plugging/sealing material	Mineral wool	Density $\geq 120 \text{ kg/m}^3$	Apply between the penetration slab and the duct
"Polochon"	Sisal + GEOPLATRE® N (or equivalent)	Mixture of Sisal fibers and bonding plaster	The mixture is applied in the slab between the penetration wall and the duct

A.2.2.5.5 Details

All installation details shall be executed as presented in figure 2.2.5.5.

ETA GEOFLAM®F Light

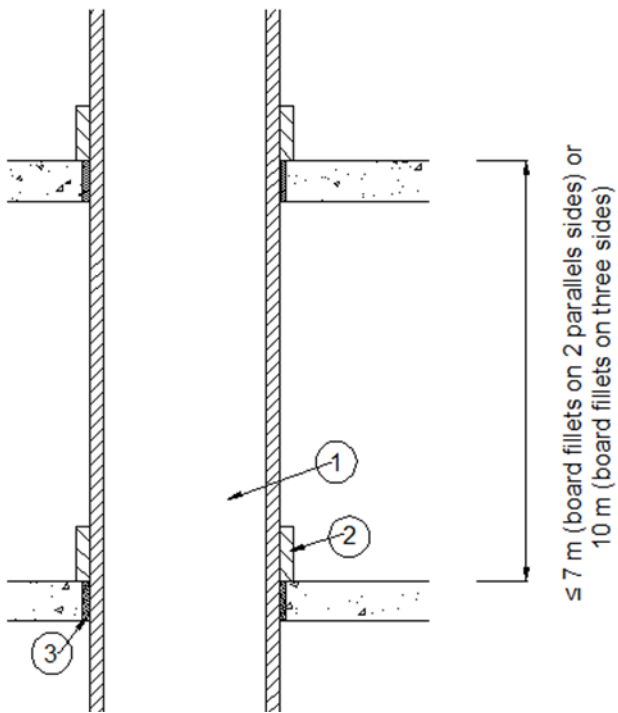

Legend:

- ① GEOFLAM® F Light boards
- ② GEOFLAM® A board fillets
- ③ gap (about 15 mm) to be filled with Rockwool, density $\geq 120 \text{ kg/m}^3$ or mixture of vegetable fibers and bonding plaster

Figure 2.2.5.5

A.2.2.5.6 Field of direct application

The results of the fire test are directly applicable to similar constructions where one or more of the changes listed below are made and the construction continues to comply with the appropriate design code for its stiffness and stability.

- The internal dimensions of the ducts are up to 1250 mm in width and up to 1000 mm in height.
- The duct is installed vertically
- The duct may penetrate concrete slabs, with a thickness superior to 150 mm and a density superior to 650 kg/m^3
- The ducts may be subject to an overpressure or an under pressure of 500Pa in case of fire

Annex 2.3: Specification of smoke extraction ducts (intended use type 9), composed of GEOFLAM® F Light fire protective boards,

A.2.3.1 Date of addition to this ETA

This annex was added to ETA 15/0653 on 2015-12-08. This assembly was not covered by this ETA prior to the addition of this annex.

A.2.3.2 Classification

The assembly described in this annex has been tested according to EN 1366-8 and classified (see table A.2.0.1) in accordance with EN 13501-4.

A.2.3.3 Installation requirements

Installation requirements in paragraph 2.2 of this ETA shall be taken into account.

A.2.3.4. Horizontal ducts

A.2.3.4.1 Supporting structure

The continuous self-supporting horizontal duct is composed of GEOFLAM® F Light fire protective boards (see paragraph A.2.3.4.3 for details of the duct composition). The duct penetrates walls with a minimum thickness of 150 mm (or a partition with an equivalent resistance to fire performance characteristics – see paragraph A.2.3.4.4.2 for details of penetration). The duct is supported by steel suspension system at intervals of 1000 mm as illustrated by figures 2.3.4.1.

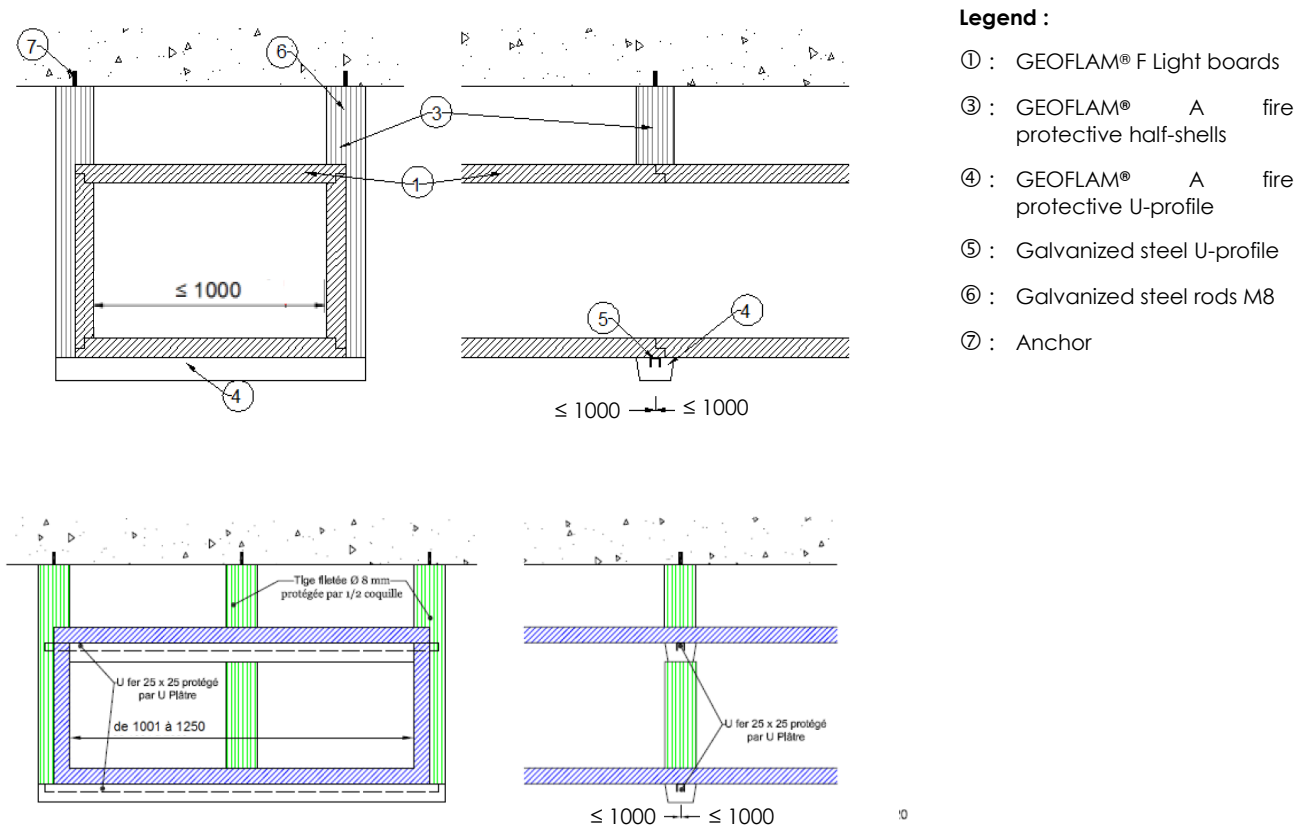

Fig. 6: Figure 2.3.4.1: Horizontal duct composed of GEOFLAM® F Light fire protective boards

The suspension system is composed with:

- Galvanized steel rods with a diameter M8
- Galvanized steel U-profiles – Dimensions : 25 x 25 x 25 x 2 mm

The supporting structure is protected whether the duct is exposed to fire from outside or from inside.

Specifications for the components are given in Table A.2.3.4.1.

ETA GEOFLAM®F Light

Table A.2.3.4.1

Element	Identification	Characteristics	Mounting and fixing
Rods	Galvanized steel rods	M8 :2 rods at a centre distance of external width + 20 mm for external width inferior to 1000 mm 1 additional rod in the middle for external width superior to 1000 mm	1000 mm centre distance
Steel U-profiles	Galvanized steel U-profiles	<ul style="list-style-type: none"> • Dimensions : 25 x 25 x 25 x 2 mm • Length : External width of the duct + 50 mm • 1 profile (under lower board of the duct) for internal duct width up to 1000 mm • 2 profiles (under lower and upper board of the duct) for internal duct width superior to 1000 mm 	1000 mm centre distance

A.2.3.4.2 Insulation

The galvanized steel rods are protected with fire protective shells (Ø 90 mm). The shells are composed of two half-pieces applied on the rods and fixed with GEOCOL® glue.

The galvanized steel U-profiles are protected with fire protective U-profiles (100 x 60 mm).

Specifications for the components are given in Table A.2.3.4.2

Table A.2.3.4.2

Element	Identification	Characteristics	Mounting and fixing
Half-shells	GEOFLAM® A	Length: 1000 mm Diameter: Ø 90 mm	Placed on steel rods and maintained with GEOCOL® glue (or equivalent)
U-profile protections	GEOFLAM® A	Length: 1000 mm Width: 100 mm Thickness: 60 mm	Placed on steel U-profiles and maintained with GEOCOL® glue (or equivalent)

A.2.3.4.3. Fire protective boards

The GEOFLAM® F Light boards are placed to form a continuous horizontal duct (see figures 2.3.1).

The boards are fixed together with GEOCOL® glue or equivalent at all edges and in the rabbets.

Maximum dimensions:

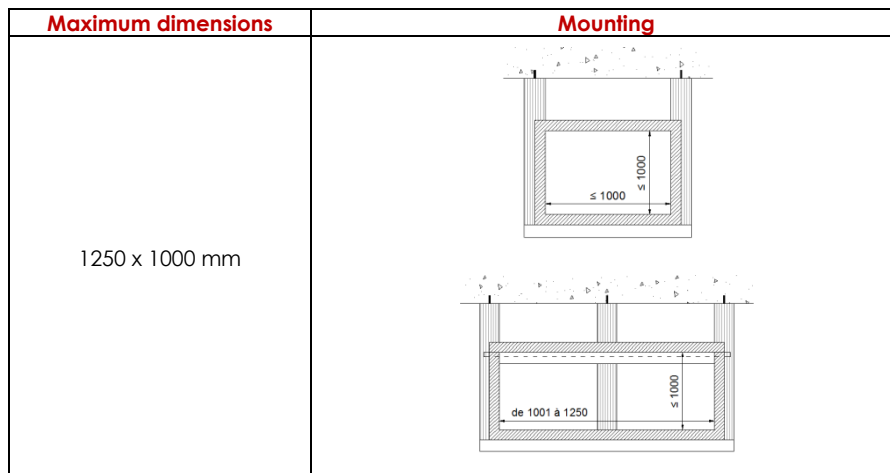

Fig. 7: Figure 2.3.4.3 : Horizontal duct composed of GEOFLAM® F Light fire protective boards

When the inner width of the duct exceeds 1000 mm, two boards must be installed on top and below the duct. In this case, another steel rod and steel U-profile have to be placed. Both steel rod and steel U-profile shall be protected with GEOFLAM® A elements (see Table A.2.3.4.2).

Specifications for the components are given in Table A.2.3.4.3.

ETA GEOFLAM®F Light

Table A.2.3.4.3

Element	Identification	Characteristics	Mounting and fixing
Board	GEOFLAM® F Light	Thickness: 35mm Length: 1000 mm Width: See table 2	Installed to form a rectangular horizontal duct
Glue	GEOCOL® or equivalent	Gypsum based adhesive, in powder form	Used for fixing of the board

A.2.3.4.4: Joints

A.2.3.4.4.1: Board joints

All internal and external joints are filled with GEOCOL® glue or equivalent and finished with a mixture of vegetable fibres and bonding plaster. The dimension of this joint finishing is 20 x 20 mm on the corners joints and 50 mm x 10 mm on all other joints.

Specifications for the components are given in Table A.2.3.4.4.1

Table A.2.3.4.4.1

Element	Identification	Characteristics	Mounting and fixing
Glue	GEOCOL® or equivalent	Gypsum based adhesive, in powder form	Applied with a spatula. The joints are completely filled up.
"Polochon"	Sisal + GEOPLATRE® N (or equivalent)	Mixture of Sisal fibres and bonding plaster	The mixture is applied on all internal and external joints. The joints are completely covered.

A.2.3.4.4.2: Penetration seal

The gap between the penetrated wall and the duct is about 15 mm on all sides of the duct. It is filled up with mineral wool (A1 classified according to EN 13501-1, density $\geq 120 \text{ kg/m}^3$) or with a mixture of vegetable fibers and bonding plaster ("Polochon") (see figure 2.3.4.4.2).

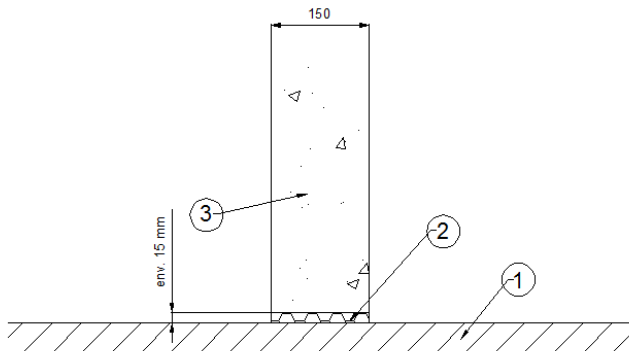

Legend:

- ① GEOFLAM® F Light boards
- ② gap (about 15 mm) to be filled with Rockwool, density $\geq 120 \text{ kg/m}^3$ or mixture of vegetable fibers and bonding plaster
- ③ Penetration wall

Figure 2.3.4.4.2

Specifications for the components are given in Table A.2.3.4.4.2

Table A.2.3.4.4.2

Element	Identification	Characteristics	Mounting and fixing
Plugging/sealing material	Mineral wool	Density $\geq 120 \text{ kg/m}^3$	The mineral wool is applied in the gap between the penetrated wall and the duct over the complete thickness of the wall
"Polochon"	Sisal + GEOPLATRE® N (or equivalent)	Mixture of Sisal fibers and bonding plaster	The "Polochon" applied in the gap between the penetrated wall and the duct over the complete thickness of the wall

A.2.3.4.5 Details

All installation details shall be executed as presented in figures 2.3.4.1. and 2.3.4.3.

A.2.3.4.6 Field of direct application

The results of the fire test are directly applicable to similar constructions where one or more of the changes listed below are made and the construction continues to comply with the appropriate design code for its stiffness and stability.

- Each of the 4 sides of the duct is composed of GEOFLAM® F Light -boards
- The internal dimensions of the ducts are up to 1250 mm in width and up to 1000 mm in height.
- The duct is installed horizontally
- The duct may penetrate walls made of bricks or concrete, with a thickness superior to 150 mm and a density superior to 650 kg/m³
- The ducts may be subject to an overpressure +500 Pa or an under pressure of -1500 Pa in case of fire

A.2.3.5. Vertical ducts

A.2.3.5.1 Supporting structure

The continuous self-supporting Vertical duct is composed of GEOFLAM® F Light fire protective boards (see paragraph A.2.3.5.3 for details of the duct composition). The duct penetrates concrete floors with a minimum thickness of 150 mm (see paragraph A.2.3.5.4.2 for details of penetration). The duct starts at ground level and penetrates a steel reinforced concrete floor (or a floor slab with an equivalent resistance to fire performance characteristics) with a minimum thickness of 150 mm. At the opening in the floor, the duct is supported by board fillets (200 mm high and same thickness as the duct) on two parallels sides (see figure 2.3.5.1). For ducts with sections composed of 4 boards, these fillets are glued to the smaller side of the duct. For ducts with sections composed of more than 4 boards, the fillets are glued to the composed sides of the duct.

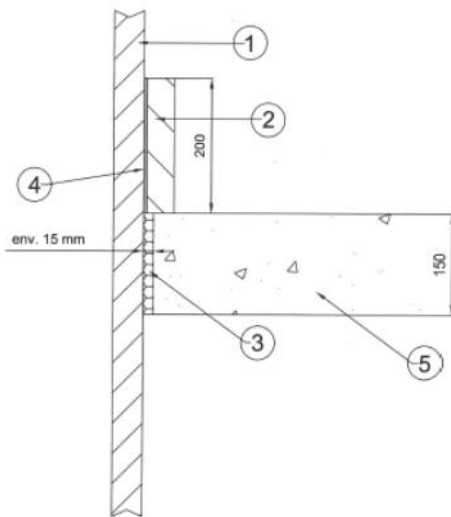

Legend :

- ① : GEOFLAM® F Light boards
- ② : GEOFLAM® A board fillets
- ③ : gap (about 15 mm) to be filled with Rockwool, density $\geq 120 \text{ kg/m}^3$ or mixture of vegetable fibers and bonding plaster
- ④ : GEOCOL® glue
- ⑤ : Steel reinforced concrete floor

Fig. 8: Figure 2.3.5.1: Vertical duct composed of GEOFLAM® F Light fire protective boards

Specifications for the components are given in Table A.2.3.5.1.

Table A.2.3.5.1

Element	Identification	Characteristics	Mounting and fixing
Board fillet	GEOFLAM® A	Thickness : Same as the duct Height : 200 mm	Glued on the duct and only supported on the concrete floor
Glue	GEOCOL® or equivalent	Gypsum based adhesive, in powder form	Used for fixing of the board fillets on the duct

NB: maximum height without supporting structure:

- 7 m (with board fillets on two parallels sides)
- 10 m (with board fillets on three sides of the duct)

A.2.3.5.2 Insulation

None

A.2.3.5.3. Fire protective boards

The GEOFLAM® F Light boards are placed to form a continuous vertical duct (see figures 2.3.5.3).

The boards are fixed together with GEOCOL® glue or equivalent at all edges and in the rabbets.

Maximum dimensions of duct are 1250 mm by 1000 mm (internal dimensions)

Specifications for the components are given in Table A.2.3.5.3

Table A.2.3.5.3

Element	Identification	Characteristics	Mounting and fixing
Board	GEOFLAM® F Light	Thickness: 35 mm Length: 1000 mm Width: See table 2	Installed to form a rectangular vertical form
Glue	GEOCOL® or equivalent	Gypsum based adhesive, in powder form	Used for fixing of the board

A.2.3.5.4: Joints

A.2.3.5.4.1: Board joints

All internal and external joints are filled with GEOCOL® glue or equivalent and finished with a mixture of vegetable fibres and bonding plaster.

Specifications for the components are given in Table A.2.3.5.4.1

Table A.2.3.5.4.1

Element	Identification	Characteristics	Mounting and fixing
Glue	GEOCOL® or equivalent	Gypsum based adhesive, in powder form	Applied with a spatula. The joints are completely filled up.
"Polochon"	Sisal + GEOPLATRE® N (or equivalent)	Mixture of Sisal fibres and bonding plaster	The mixture is applied on all internal and external joints. The joints are completely covered.

A.2.3.5.4.2: Penetration seal

The gap between the slab and the duct is filled up with mineral wool (A1 classified according to EN 13501-1, density ≥ 120 kg/m³) or with a mixture of vegetable fibers and bonding plaster (see figure 2.3.5.5).

Specifications for the components are given in Table A.2.3.5.4.2

Table A.2.3.5.4.2

Element	Identification	Characteristics	Mounting and fixing
Plugging/sealing material	Mineral wool	Density ≥ 120 kg/m³	Apply between the penetration slab and the duct
"Polochon"	Sisal + GEOPLATRE® N (or equivalent)	Mixture of Sisal fibers and bonding plaster	The mixture is applied in the gap between the penetration slab and the duct

A.2.3.5.5 Details

All installation details shall be executed as presented in figure 2.3.5.5.

ETA GEOFLAM®F Light

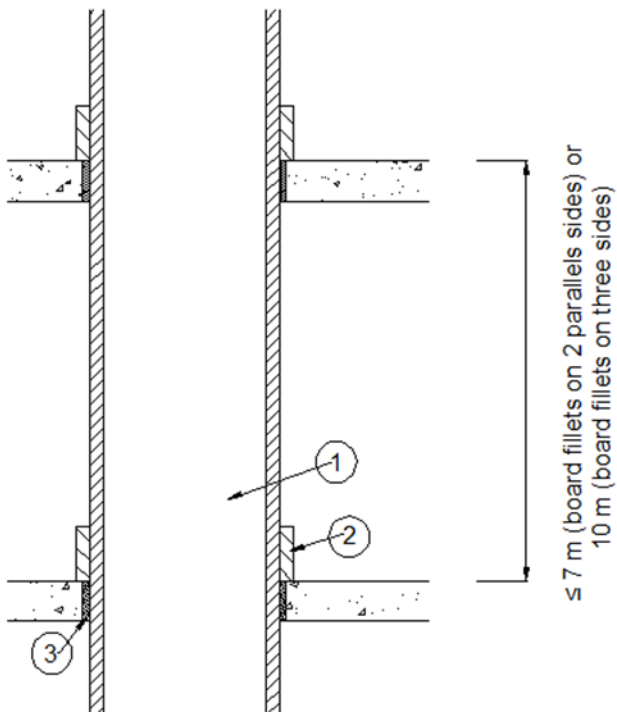

Legend:

- ① GEOFLAM® F Light boards
- ② GEOFLAM® A board fillets
- ③ gap (about 15 mm) to be filled with Rockwool, density $\geq 120 \text{ kg/m}^3$ or mixture of vegetable fibers and bonding plaster

Figure 2.3.5.5

A.2.3.5.6 Field of direct application

The results of the fire test are directly applicable to similar constructions where one or more of the changes listed below are made and the construction continues to comply with the appropriate design code for its stiffness and stability.

- The internal dimensions of the ducts are up to 1250 mm in width and up to 1000 mm in height.
- The duct is installed vertically
- The duct may penetrate concrete slabs, with a thickness superior to 150 mm and a density superior to 650 kg/m^3
- The ducts may be subject to an overpressure +500 Pa or an under pressure of -1500 Pa in case of fire